



*i***Polymer**
by White Knight

International Polymer Solutions



Proud Manufacturer Of High-Purity Fluid Handling Products

iPolymer manufactures high-purity fluid handling solutions for use in semiconductor, solar, pharmaceutical, biomedical, life sciences, food processing, clean-room laboratory, chemical handling, and more!

www.ipolymer.com | info@ipolymer.com



About iPolymer

International Polymer Solutions (iPolymer) has extensive experience manufacturing high-quality, ultrapure fluid handling products. Our products are used in a variety of industries, including semiconductor, gas analytics, bio-medical, pharmaceutical, food and sanitary process, water purification, high-purity laboratory, and other general chemical handling environments.

iPolymer's dedicated teams strive to provide unsurpassed customer satisfaction. Our skilled craftsmen are experts in a wide variety of plastic machining and fabrication techniques utilizing state-of-the-art CNC Machining, Routing and Plastic Welding equipment. Engineering Support includes Solidworks 3D modeling, MasterCAM, In-house laboratory testing and FEA analysis.

Our extensive product offering consists of pneumatic valves, solenoid valves, manual valves, air cylinders, spray guns, fittings and connectors, and custom fabricated solutions, such as process tanks, containment vessels, clean room enclosures, storage boxes, manifolds, cabinets and flow benches. Our products include PTFE, PFA, PVDF, PEEK, CPVC, Polypropylene and other specialized polymers to fit your requirements.

iPolymer acquired BECO Manufacturing in 2010 and TEQCOM Industries in 2011. iPolymer was acquired by White Knight Fluid Handling in 2024.

Warranty Statement

White Knight follows strict manufacturing, assembly and testing procedures to ensure consistency and reliability.

White Knight warrants products and components are free from defects in materials and workmanship. Warranty duration depends on product type and starts from our shipment date or your installation date if provided within 90 days of shipment from our facility.

Failures due to normal wear, misuse, abuse or unauthorized disassembly nullify this warranty.

White Knight does not guarantee the suitability of products for specific applications. White Knight is not liable for any damage or expense resulting from use or misuse of its products in any application. Responsibility is limited solely to repair or replacement of defective products or components.

Prior written, faxed or emailed approval must be obtained from White Knight before returning any product or component for warranty consideration. All determinations regarding cause of failure are made by White Knight, and all decisions regarding warranty fulfillment or nullification are made by White Knight.

THE FOREGOING WARRANTY IS EXCLUSIVE AND IN LIEU OF ALL OTHER WARRANTIES EXPRESSED OR IMPLIED, INCLUDING ANY GUARANTEE OF SUITABILITY FOR ANY PURPOSE. NO VARIATIONS OF THIS WARRANTY SHALL BE HONORED NOR CONSIDERED LEGALLY BINDING, EXCEPT WRITTEN AGREEMENTS SIGNED BY THE CEO OF WHITE KNIGHT FLUID HANDLING.



Contents

About iPolymer.....	2	Fittings & Connectors.....	32
Warranty Statement.....	2	Tube Fittings.....	34
High-Purity Valve Manifolds.....	4	• Barbed Fitting.....	34
High-Purity Valves.....	5	• Female Connector.....	34
Ball Valve.....	6	• Bulkhead Female Connector.....	34
Stopcock Valves.....	7	• Bulkhead Union.....	34
HPV Diaphragm Valve.....	8	• Female Run Tee.....	35
PTFE Pneumatic Valves.....	10	• Female Elbow.....	35
Mini Pneumatic Diaphragm Valves.....	12	• Bulkhead Male Connector.....	35
Chemical Resistant Valves.....	14	• Male Connector.....	35
Inline Diaphragm Valves.....	16	• Tube Nut.....	35
Suckback Valves.....	17	• Male Branch Tee.....	36
DI Water Valve.....	18	• Male Run Tee.....	36
Water Valve.....	19	• Male Elbow.....	36
Drain Valve.....	20	• Tube Cap.....	36
Quick Dump Valves.....	21	• Reducing Union.....	37
Check Valves.....	22	• Union Elbow Reducer.....	37
Pressure Relief Valve.....	23	• Union.....	37
Miniature Solenoid Valves.....	24	• Union Tee.....	37
Spray Guns.....	26	• Union Elbow.....	37
Dilution Drain Valves.....	28	• Union Cross.....	37
Aspirators.....	29	Flare Fittings.....	38
Air Cylinders.....	30	• Male Elbow.....	38
Gauge Isolator.....	31	• Female Elbow.....	38
		• Union.....	38
		• Reducing Union.....	38
		• Bulkhead Union.....	38
		• Union Tee.....	39
		• Union Elbow.....	39
		• Flare Nut.....	39
		• Male Connector.....	39
		• Female Connector.....	39
		Pipe Fittings.....	40
		• Bushing.....	40
		• Short Bushing.....	40
		• Female Reducer.....	40
		• Pipe Nipple.....	40
		• Elbow.....	40
		• Coupling.....	40
		• Street Elbow.....	40
		• Nipple Pipe Reducer.....	40
		• Pipe Plug.....	40
		Engineer Reference.....	41
		• Materials & Chemical Compatibility.....	41
		• Common Polymers & Uses.....	41

iPolymer | High-Purity Valve Manifolds

High-Purity Valve Manifolds for Aggressive Chemicals

iPolymer High-Purity Valve Manifolds (HVM) feature 100% virgin PTFE, PFA and M112 wetted flow path ideally suited for aggressive chemical applications common in Semiconductor valve boxes and distribution systems. Their simple, nonmetallic construction consist only of PTFE, PVDF, PFA and PEEK ensuring reliable, long lasting performance. The primary Manual valve directs flow from the common ports to the process port (typically North) and the drain valve allows the operator to purge or sample the process (typically South). iPolymer HVM-8 and HVM-12 are direct replacements for the Parker MV-8 Series valves.



Specifications

Port	HVM-8	Cv
Common	3/4-in Flare Male / Female	15
Process	1/2-in Flare Main Valve	2.5
Drain	1/2-in Flare Secondary Valve	0.3

Port	HVM-12	Cv
Common	3/4-in Flare Male / Female	35
Process	1-in Flare Main Valve	9.6
Drain	1/2-in Flare Secondary Valve	0.3

Highlights

- Media Pressure: 80 psi maximum
- Media Vacuum: 25 in Hg
- Media Temperature: 0° - 100°C (32° - 212°F)
- Ambient Temperature: 0° - 60°C (32° - 140°F)
- Offered in many unique configurations (consult factory)
- Standard Flare or Fit-Line Global Nexus™ connections

Materials of Construction

- 100% virgin PTFE and M112 flow path
- Exterior components are PTFE
- Valve handles and locking rings are PVDF
- Universal fittings and nuts are PFA
- No metals – all hardware and pins are PEEK

Dimensions

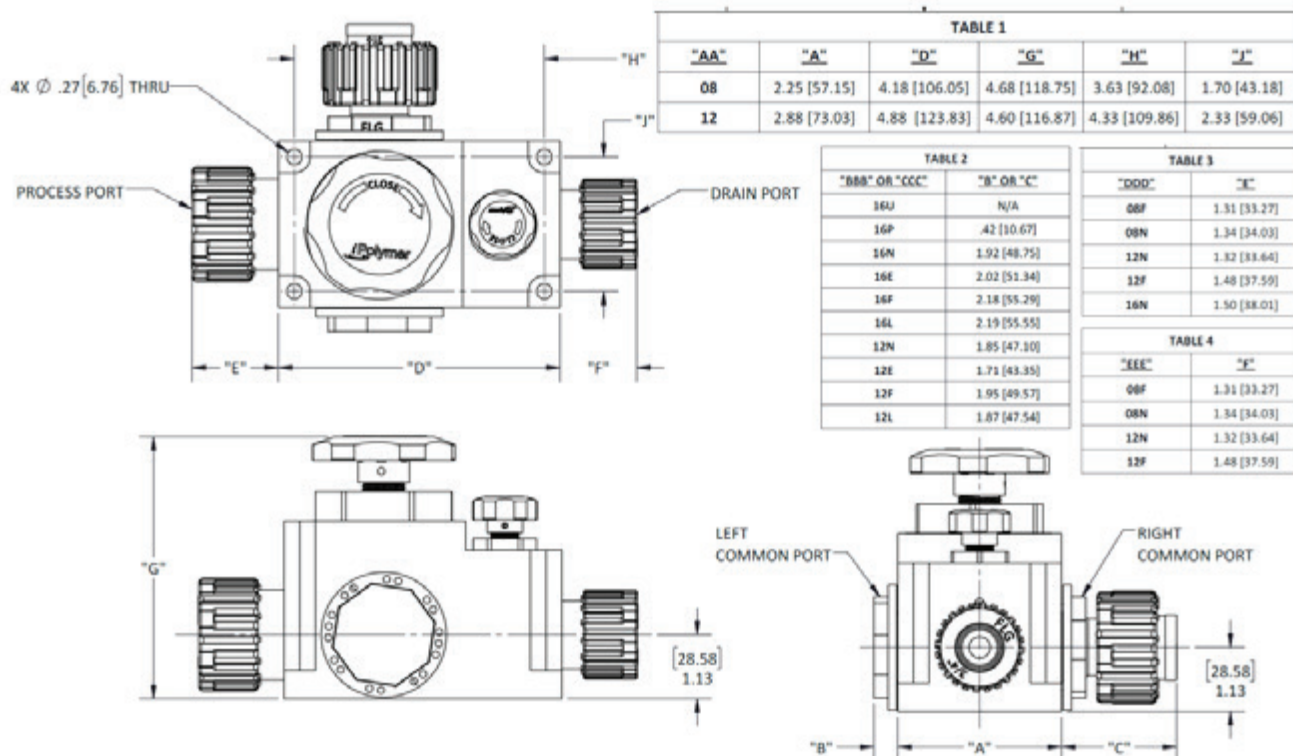

iPolymer | High-Purity Valves

High-Purity Valves for Aggressive Chemicals & High Temperatures

iPolymer High-Purity Valves (HV) feature 100% virgin PTFE and M112 wetted flow paths ideal for high-purity, high-temperature applications. The HV Series is a multi-turn diaphragm valve available in 1/4, 1/2 and 3/4-in sizes. The simple, nonmetallic external construction consist of only PTFE, PVDF and PEEK to ensure reliable, long-lasting performance in the most aggressive environments. Common applications include DI water, aggressive chemistry distribution, and safety shutoff.



Highlights

- 100% virgin PTFE and M112 wetted flow path
- Max. media tressure: 80 psi
- Media vacuum: 25 in Hg
- Media temperature: 0° - 100°C (32° - 212°F)
- Ambient temperature: 0° - 60°C (32° - 140°F)
- 2-Way, multi-turn configurations
- Standard Flare or Fit-Line Global Nexus™ connections

Specifications

Part	Size (in)	Port Type	Port (in)	Configuration
HV-0404F	1/4	Flare	1/4	Multi-Turn
HV-0404N	1/4	Nexus	1/4	Multi-Turn
HV-0406F	1/4	Flare	3/8	Multi-Turn
HV-0406N	1/4	Nexus	3/8	Multi-Turn
HV-0808F	1/2	Flare	1/2	Multi-Turn
HV-0808N	1/2	Nexus	1/2	Multi-Turn
HV-0812F	1/2	Flare	3/4	Multi-Turn
HV-0812N	1/2	Nexus	3/4	Multi-Turn
HV-1212F	3/4	Flare	3/4	Multi-Turn
HV-1212N	3/4	Nexus	3/4	Multi-Turn
HV-1216F	3/4	Flare	1	Multi-Turn
HV-1216N	3/4	Nexus	1	Multi-Turn

Max. Media Pressure	80 psi
Media Vacuum	25 in Hg
Media Temperature	0° - 100°C (32° - 212°F)
Ambient Temperature	0° - 60°C (32° - 140°F)
Actuation Pressure (psi)	45 - 60

Cross Section

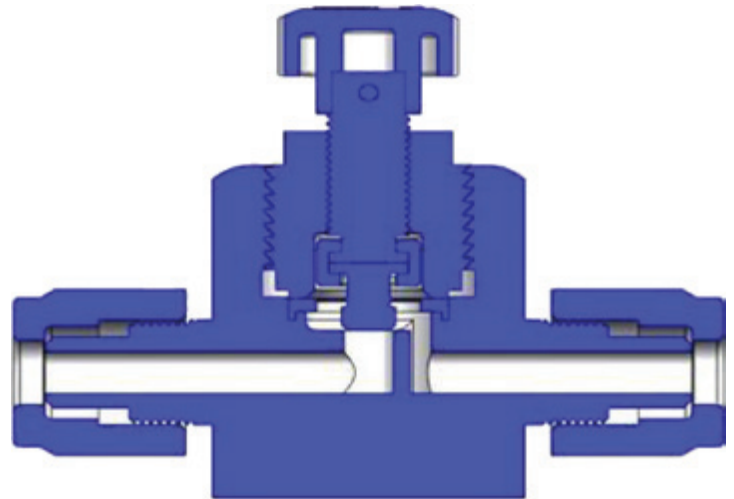

iPolymer | Ball Valve

Ball Valve

Ball Valve features an all PTFE wetted surface design. The design is ideal for harsh chemical and corrosive media applications. PTFE is also well suited to clean room and deionized water applications. The body, stem, ball and ports are constructed from PTFE. For standard applications, external non-wetted components are constructed from Natural PVDF and Polypropylene.



Highlights

- PTFE construction for media wetted surfaces
- Reliable low torque manual operation
- Quarter-turn with positive stops
- Design accommodates partial open position for metered flow
- All models can be panel mounted
- All models can be used in high ambient temperature environments

Specifications

Standard Port Sizes (in)	1/4, 3/8, 1/2, 3/4, or 1
Connection Types	FNPT or Nexus
Max. Media Operating Pressure (psi)	120 25 in Hg vacuum
Media Operating Temperature Range	32 - 212°F (0 - 100°C)
Ambient Temperature Range	32 - 140°F (0 - 60°C)

Dimensions

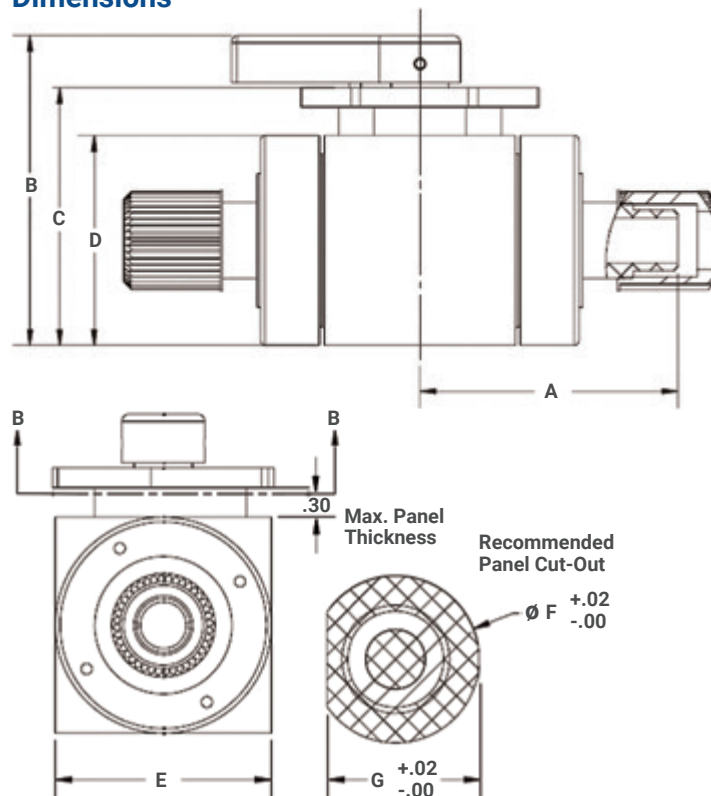

Part	Port Size (in)	End Connection	Dim A	Dim B	Dim C	Dim D	Dim E	Dim F	Dim G
BV-44-P	1/4	FNPT	1.62	3.18	2.50	2.00	2.00	1.82	1.69
BV-44-N	1/4	Nexus	2.10	3.18	2.50	2.00	2.00	1.82	1.69
BV-66-P	3/8	FNPT	1.62	3.18	2.50	2.00	2.00	1.82	1.69
BV-66-N	3/8	Nexus	2.27	3.18	2.50	2.00	2.00	1.82	1.69
BV-88-P	1/2	FNPT	1.62	3.18	2.50	2.00	2.00	1.82	1.69
BV-88-N	1/2	Nexus	2.44	3.18	2.50	2.00	2.00	1.82	1.69
BV-1212-P	3/4	FNPT	2.13	4.06	3.38	2.75	2.75	2.13	1.94
BV-1212-N	3/4	Nexus	3.12	4.06	3.38	2.75	2.75	2.13	1.94
BV-1616-P	1	FNPT	2.13	4.06	3.38	2.75	2.75	2.13	1.94
BV-1616-N	1	Nexus	3.29	4.06	3.38	2.75	2.75	2.13	1.94

Nexus connections are Pillar S-300 Compatible

iPolymer | Stopcock Valves

Stopcock Valves

Stopcock Valves are precision machined devices that function in much the same way as a ball valve. When the handle points in the direction of flow, the valve is fully open; when the handle points perpendicular to the direction of flow, the valve is fully closed; and at the 45° position the valve is halfway open and thereby has a metering effect on the media flow.

iPolymer Stopcocks feature an all PTFE wetted surface design that is ideal for harsh chemical and corrosive media. PTFE is also well suited to clean room environments and deionized water applications.

The body, stem and ports are constructed from PTFE. For standard applications, external non-wetted components are constructed from Polypropylene. All configurations are optionally available as Panel Mounted and/or High Ambient Temperature models.

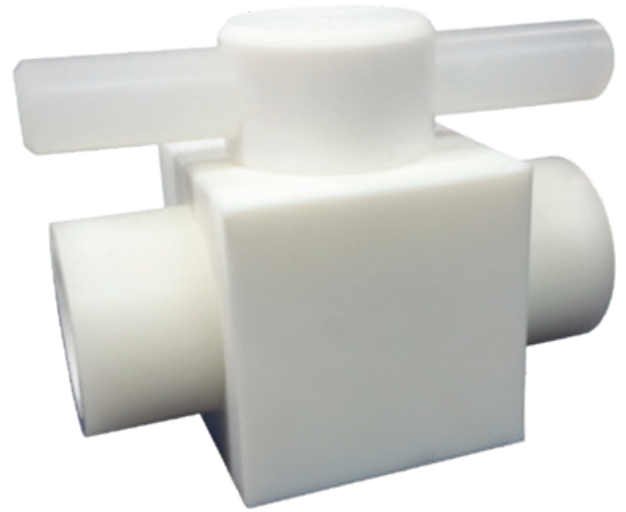

Valve Stem Options

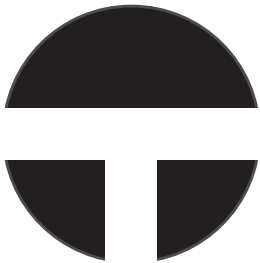

Type -T
3-way

Dimensions

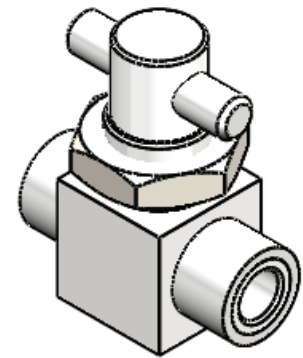
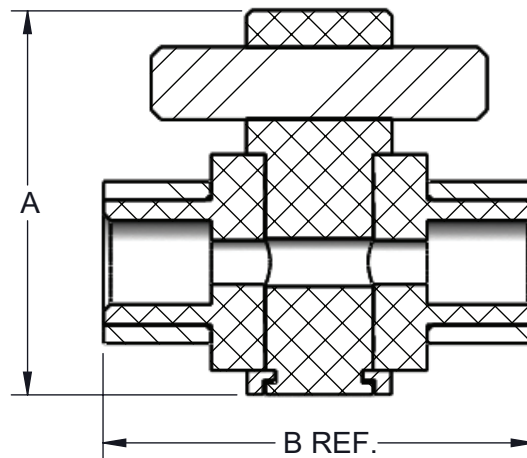
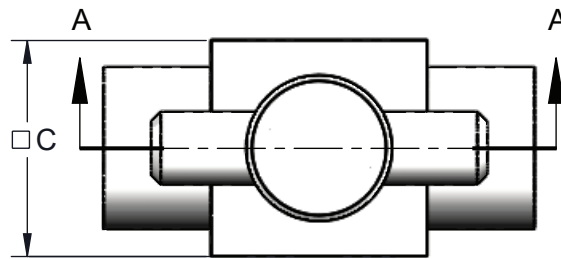

PANEL MOUNT OPTION

Specifications

Media Pressure (psi)	60
Media temperature	100° C / 212° F
Ambient temperature	60° C / 140° F
Wetted Surfaces	Virgin PTFE

Part	Port Size (in)	Port Type	Configuration	Orifice (in)	Stem Type	Mount	Hard Stop	A	B	C	PM Hole Size	Max. Panel Thickness
SC-403	1/8	Tube	2-WAY	0.09	N/A	Standard	N/A	1.63	1.76	1.00	0.70	0.30
SC-500	1/4	FNPT	2-WAY	0.23	N/A	Standard	N/A	2.00	2.25	1.13	0.90	0.30
SC-507-T-P	1/4	Flare	3-WAY	0.13	T	Panel Mount	N/A	2.00	2.25	1.69	0.90	0.30
SC-600	3/8	FNPT	2-WAY	0.28	N/A	Standard	N/A	2.13	2.62	1.50	1.03	0.43
SC-700	1/2	FNPT	2-WAY	0.44	N/A	Standard	N/A	2.33	3.25	1.88	1.40	0.43
SC-712-P-HS	1/2	FNPT	2-WAY	0.44	N/A	Panel Mount	1/4 Turn	3.33	3.25	1.88	1.40	0.43

HS = 1/4-Turn Hard Stop. Add ~3/8" per port for Flared Connections.

iPolymer | HPV Diaphragm Valve

HPV Diaphragm Valve

HPV Diaphragm Valves are used in high-purity water and aggressive chemical applications. HPV has 100% virgin PTFE wetted flow path ideal for DI Water systems and corrosive media used in semiconductor, solar, pharmaceutical, and chemical process applications. HPV valves are ideal for custom manifold systems that combine many high-purity components into a compact, easy-to-install, integrated solution. iPolymer custom manifolds are designed to reduce leak points and pressure drops. They come fully tested and ready to install.

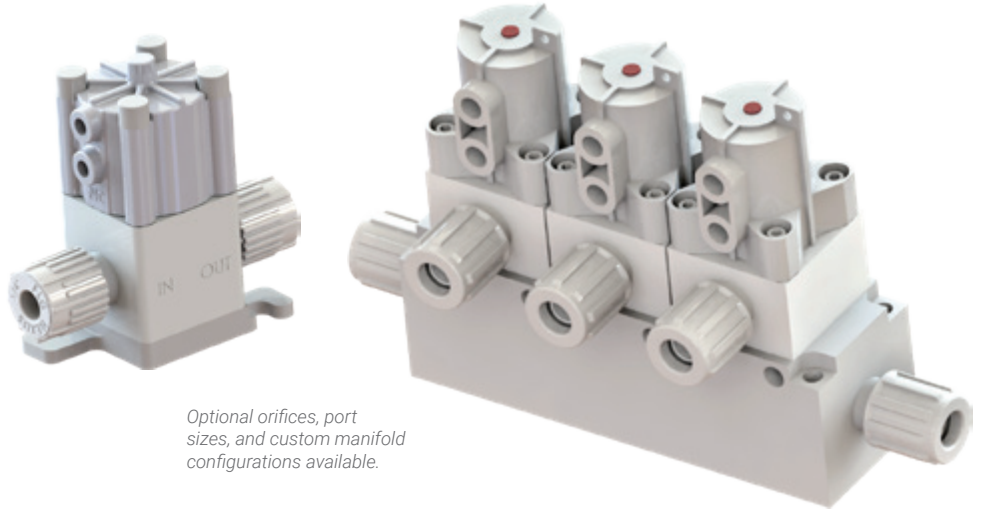

Highlights

- 100% virgin PTFE and M112 wetted flow path
- Media Pressure: 80 psi maximum
- Actuation Pressure: 50-80 psi
- Media Vacuum: 25 in Hg
- Media Temperature: 0 - 80°C (32 - 176°F)
- Ambient Temperature: 0 - 60°C (32 - 140°F)
- Flow coefficient, Cv= 0.68
- Offered in 2-Way and 3-Way configurations
- Flare or Fit-Line Global Nexus™ connections

Specifications

Part	Inlet (in)	Port Type	Outlet (in)	Config.
HPV-04-NC-04-F	1/4	Flare	1/4	2-Way, NC
HPV-04-NC-06-F	1/4	Flare	3/8	2-Way, NC
HPV-04-NO-04-F	1/4	Flare	1/4	2-Way, NO
HPV-04-NO-06-F	1/4	Flare	3/8	2-Way, NO
HPV-04-MT-04-F	1/4	Flare	1/4	Multi-Turn
HPV-04-MT-06-F	1/4	Flare	3/8	Multi-Turn
HPV-04-NC-04-N	1/4	Nexus	1/4	2-Way, NC
HPV-04-NC-06-N	1/4	Nexus	3/8	2-Way, NC
HPV-04-NO-04-N	1/4	Nexus	1/4	2-Way, NO
HPV-04-NO-06-N	1/4	Nexus	3/8	2-Way, NO
HPV-04-MT-04-N	1/4	Nexus	1/4	Multi-Turn
HPV-04-MT-06-N	1/4	Nexus	3/8	Multi-Turn
HPV-04-NC-04-P	1/4	FNPT	1/4	2-Way, NC
HPV-04-NO-04-P	1/4	FNPT	1/4	2-Way, NO
HPV-04-MT-04-P	1/4	FNPT	1/4	Multi-Turn

HPV are configured with their maximum available port orifice for the given port style and size. Contact us for constrained orifices, custom configurations, and other custom solutions.

Performance

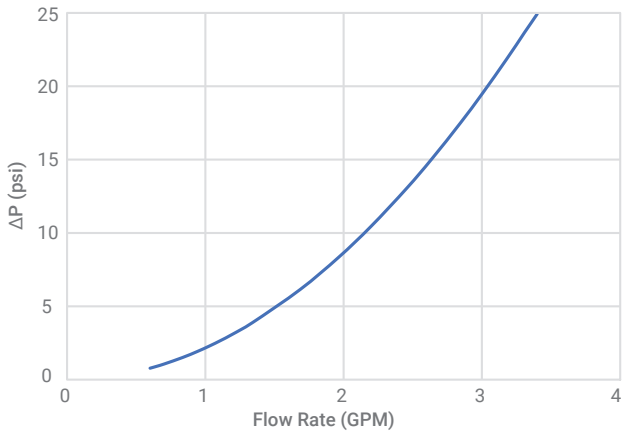

Temperatures

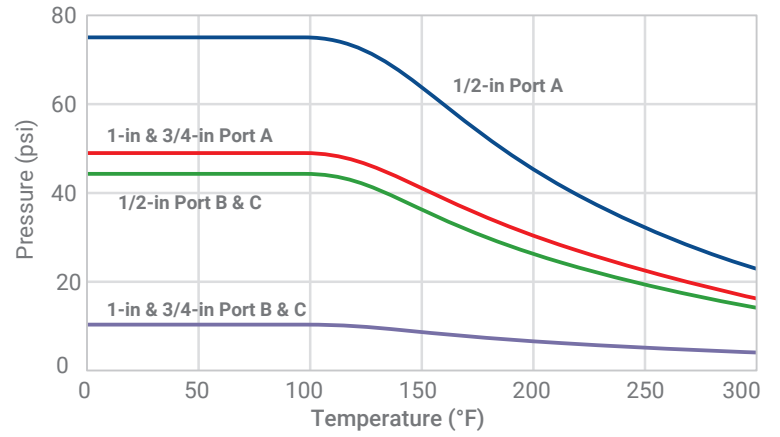

Dimensions

ACTUATION PORTS
10-32 UNC THREAD

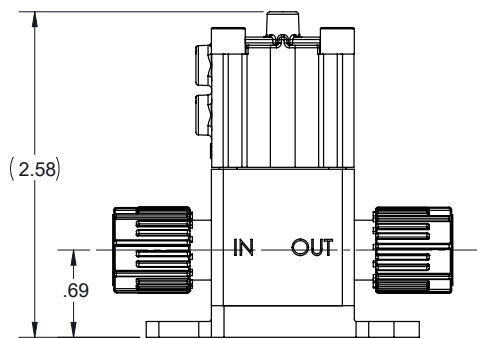
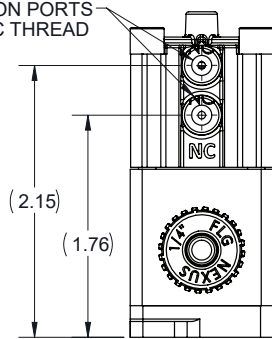

HPV-04-NC-04N

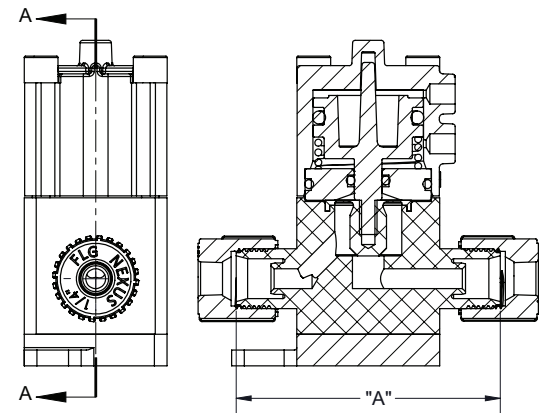

HPV-04-NO-04N

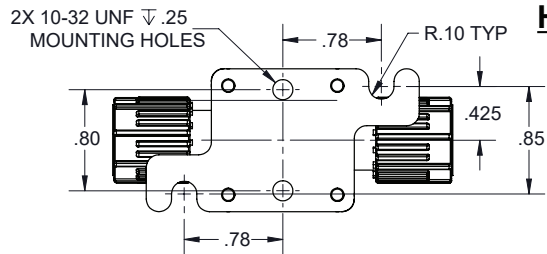

iPolymer | PTFE Pneumatic Valves

PTFE Pneumatic Valves

PTFE Pneumatic Valve (TP Valve) features an all PTFE wetted surface design. The design is ideal for harsh chemical and corrosive media and environments. PTFE is well suited for clean room and deionized water applications.

Highlights

- One-piece PTFE body
- Optimum anti-corrosion design
- High-temp version with PVDF components is available
- Complete media isolation



Applications

- Chemical Neutralization
- Chemical Delivery
- DI Water Rinse
- Wafer Etching
- Acid Parts Cleaning
- Phosphoric Acid Nitride Removal
- Sulfuric Peroxide Stripping
- Potassium Hydroxide Etching

Specifications

Materials			
Body	PTFE		
Bellows/Poppet	PTFE		
Backing Plate	PTFE		
Piston	Polypropylene		
Cap	Polypropylene		
Orifice Size	1/2"	3/4"	1"
Cv	2.2	2.8	7.5
Port A Max. Pressure (psi)	75	50	50
Port B Max. Pressure (psi)	45	10	10
Actuator Pressure Range (psi)	50 - 80	50 - 80	50 - 80
Max. Media Temperature	212° F / 100°C HT 300°F / 149°C		

Specifications are for both normally-open and normally-closed configurations. See Pressure vs. Temperature graph for full range. Port C reference for 3-Way only.

Performance

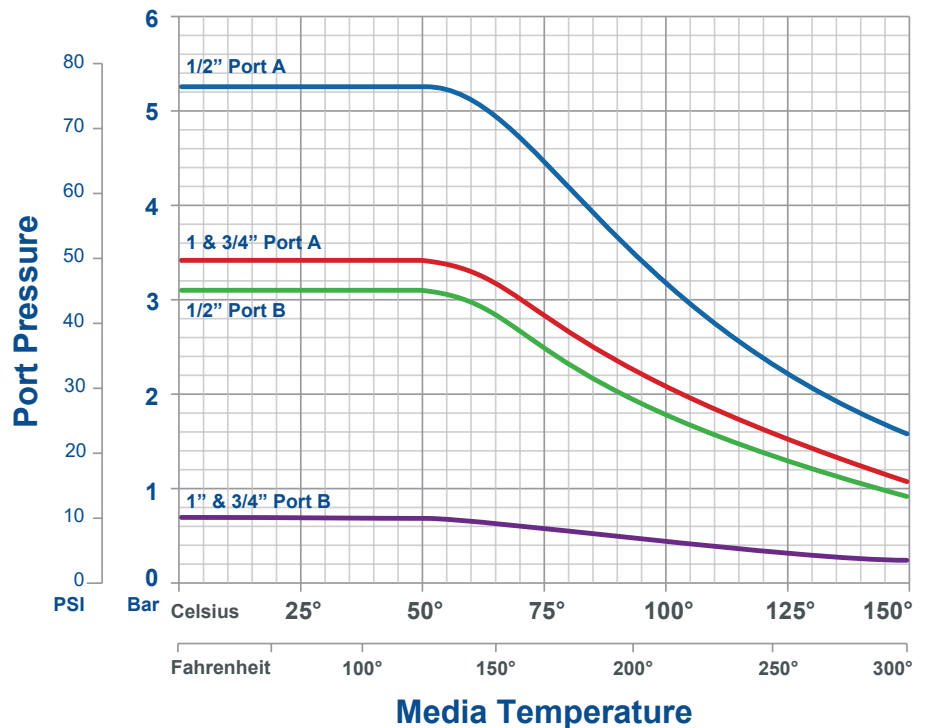

Ordering Format

TP - 2W - 8 P - XX - RC
0 1 2 3 4 5

0. Valve Series

TP = PTFE Pneumatic Valve

1. Valve Configuration

2W = 2-Way

2. Ports / Orifice Size

8 = 1/2"

12 = 3/4"

16 = 1"

3. Port Connection

P = Female Pipe (FNPT)

4. Port Configuration

For 2-Way:

C = 2-Way Normally Closed

O = 2-Way Normally Open

5. Flow Options

RC = Restricted Closure

RO = Restricted Open

AB = Anti-Bacteria Feature (MAH)

MA = Micro Adjust Feature

**Restrictive Flow options are only available for Normally Closed valves.*

Port A, B	C	D	E	F	G	H
1/4"	3.56	2.48	1.18	2.19	0.70	0.53
3/4"	5.61	3.56	1.94	3.65	1.21	0.85
1"	5.61	3.56	1.94	3.65	1.21	0.85

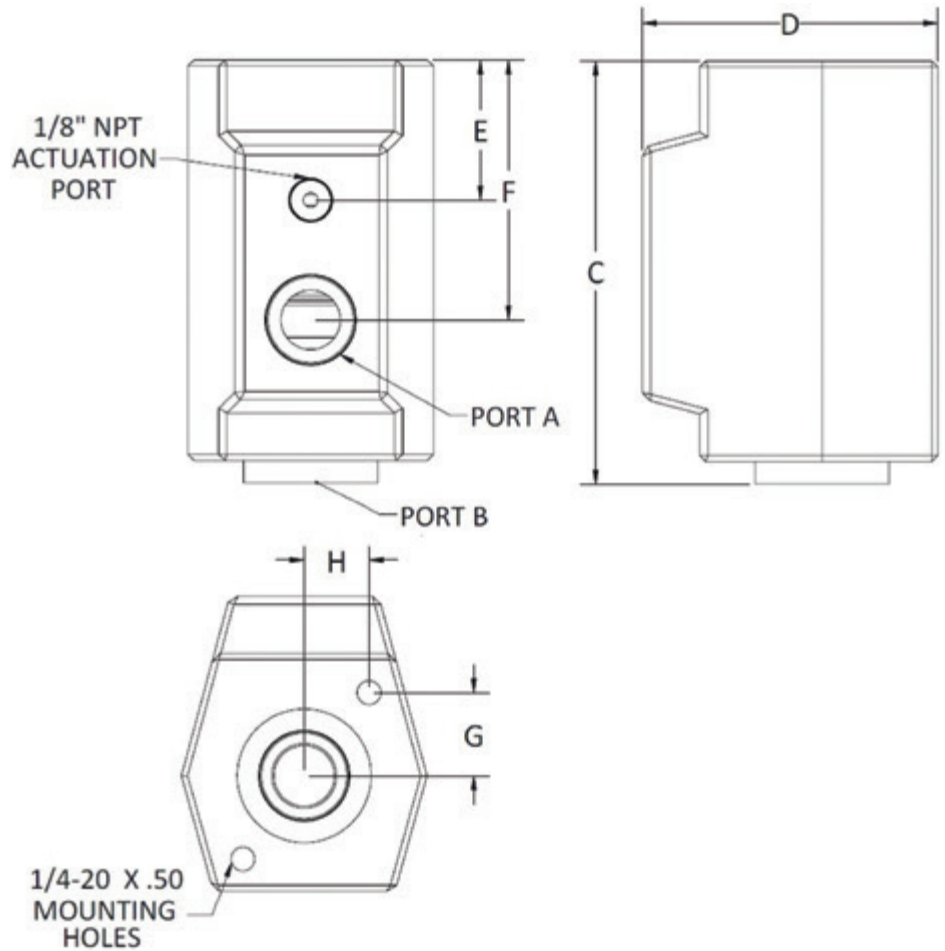

AB Option

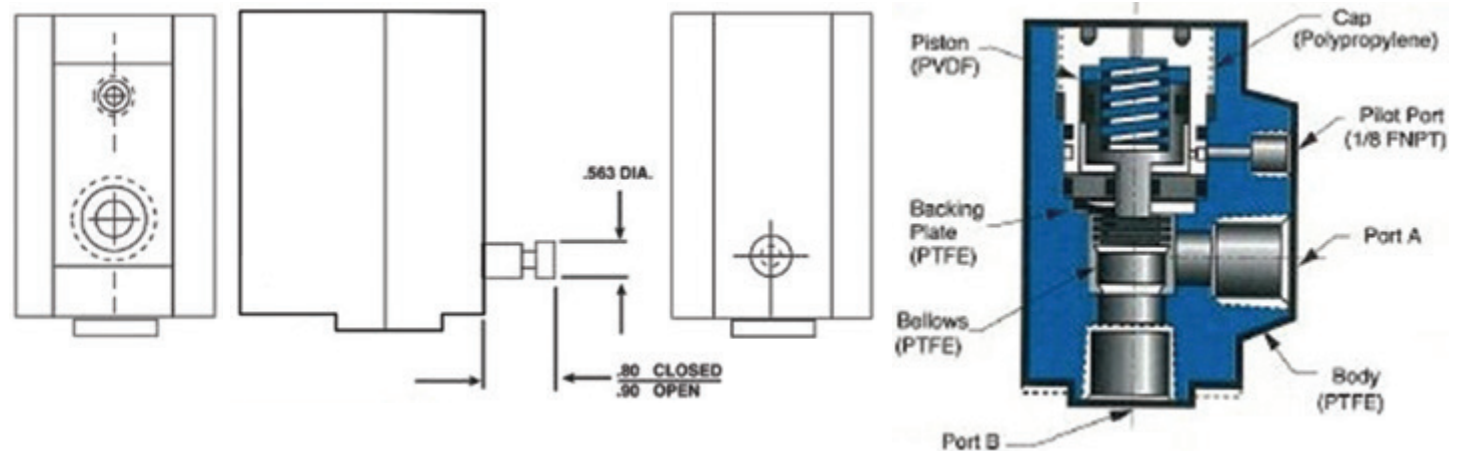

iPolymer Product Notes:

1. Please email Customer Service at info@ipolymer.com
2. Call us for special applications. We can manufacture our Valves with special mounting and interface dimensions.
3. Alternate materials are available that may allow for expanding temperature ratings or other performance characteristics.
4. Unauthorized disassembly will void the original factory one-year product warranty. Contact us or your Distributor for details.

iPolymer | Mini Pneumatic Diaphragm Valves

Mini Pneumatic Diaphragm Valves

Miniature Pneumatic Diaphragm Valves offer precision performance under extreme conditions. Offered as 2-Way and 3-Way valves with four internal body configurations and three valve seat sealing methods, these valves are suitable for ultra-clean to highly corrosive media applications. Their PTFE flow paths are ideal for semiconductor, pharmaceutical, biomedical and chemical process applications. Configurable with a PTFE Hard Seat, FKM (Viton Eq.) O-Ring Seat or FFKM (Kalrez Eq.) O-Ring Seat the valves provide unsurpassed chemical compatibility for a variety of media. The PTFE body, valve stem and one-piece diaphragm maintain a material inert boundary for ultra-clean applications.



Highlights

- PTFE design optimized for ultra-clean and chemical compatibility
- Lightweight pneumatic actuator with compact valve design
- Pneumatic actuator available in standard polypro or high-temp models
- PTFE diaphragm completely isolates media from the actuator
- 100% pneumatic driven – does not require power only supply air
- O-ring seat configurations for vacuum and complex media applications
- Designed for aggressive media and elevated temperature

Custom Options

- Valves with special port connections such as combinations of pipe, tube and flared ends
- Valves without mounting studs or valves with 4 mounting studs (2 are standard)
- Manifold valve assemblies

Specifications

General Valve Parameters	
1/8" Orifice Cv (2W-NC, 2W-NO, 3W)	0.35 / 0.18 / 0.18
1/4" Orifice Cv (2W-NC, 2W-NO, 3W)	0.60 / 0.35 / 0.35
3/8" Orifice Cv (2W-NC, 2W-NO, 3W)	0.90 / 0.60 / 0.60
Common Port Vacuum in-Hg (max)	25
Actuator Pressure (range)	40 - 60 psi
Media Temperature (range)	0 - 80°C / 32 - 176°F
Ambient Temperature (range)	0 - 60°C / 32 - 140°F
Max. Port Pressure Rating	3-Way
Common Port	60 psi
Normally Closed Port	30 psi
Normally Open Port	60 psi
2-Way NC	
Inlet Port	60 psi
Outlet Port	30 psi
2-Way NO	
Inlet Port	60 psi
Outlet Port	60 psi



3/8" 3-Way FNPT



1/4" 3-Way Tube



1/4" 2-Way FNPT

Custom Manifold Assemblies

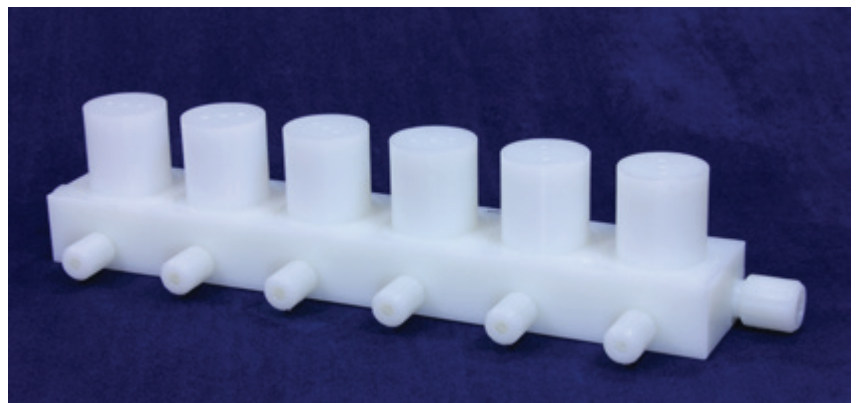

Ordering Format

MTV - 12 2C F S - T - 123
 0 1 2 3 4 5 6

0. Valve Series

MTV = Miniature Pneumatic Diaphragm

1. Ports / Max. Orifice

- 22 = 1/8" FNPT, 1/8" Orifice
- 44 = 1/4" FNPT, 1/4" Orifice
- 66 = 3/8" FNPT, 3/8" Orifice
- 88 = 1/2" FNPT, 3/8" Orifice
- 21 = 1/8" Tube, 1/16" Orifice
- 43 = 1/4" Tube, 3/16" Orifice
- 65 = 3/8" Tube, 5/16" Orifice
- 86 = 1/2" Tube, 3/8" Orifice
- 42 = 1/4" Flare, 1/8" Orifice
- 64 = 3/8" Flare, 1/4" Orifice
- 86 = 1/2" Flare, 3/8" Orifice

2. Valve Configuration

- 2C = 2-Way Normally Closed
- 2O = 2-Way Normally Open
- 3W = 3 Way (See Port Arrangements)

3. Port Selection

- F = Female NPT
- T = Tube Ends
- FF = Flare Ends

4. Body Shape

- S = Square

5. Valve Seat

- T = PTFE
- V = FKM (Viton Eq.)
- K = FFKM (Kalrez Eq.)
- E = EPDM

5. Port Arrangement

- (Only for 3-way config.)
- 123 = NC-C-NO
- 132 = NO-C-NC

Contact us for custom configurations.

Top View of Coil

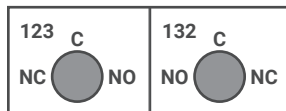

Auxiliary Plate ("AP")

For highly corrosive or caustic gas applications, such as Chlorine Gas, our Auxiliary Plate Option ("-AP") give an extra line of protection. The valve is configured with an auxiliary plate between the upper diaphragm and solenoid coil. The AP (Auxiliary Plate) is ORing sealed on the Stem of the diaphragm and supported at the outer body-to-coil interface.

Typical for 3/8" and 1/2" Models

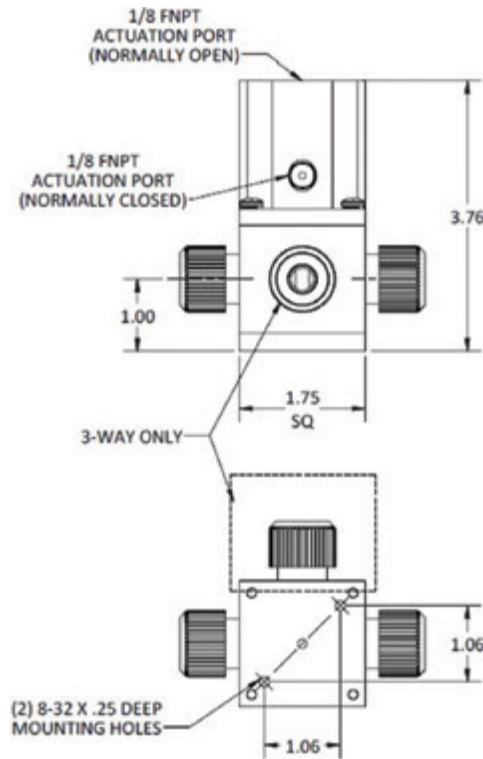

Typical for 1/8" and 1/4" Models

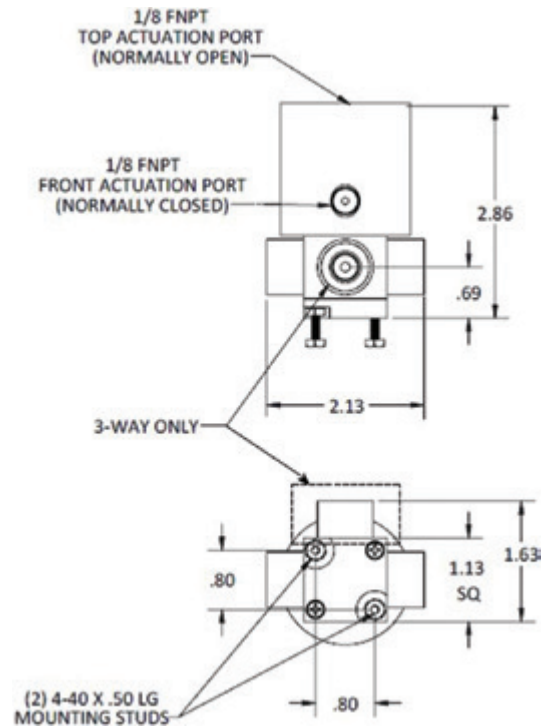

iPolymer | Chemical Resistant Valves

Chemical Resistant Valves

Chemical Resistant (CR) Valves offer chemical and corrosion control through a complete fluoroplastic design and construction. All wetted surfaces are manufactured from virgin PTFE. Pneumatic Actuator, Base and Bands are constructed from PVC, Polypropylene or PVDF. The polymer components selected for CR Valve line are specifically suited for use with ultrapure water, deionized water, solvents, chemicals and liquid flowing bio-matter. Our PTFE Bellows-style valve stem and PTFE valve seat help ensure the valve self-flushes a wide variety of flowing media. Special custom configurations are available on request. These include: manifold valve assemblies with multiple ports and high ambient temperature pneumatic actuators.



Specifications

Size	1/4"	3/8"	1/2"	3/4"	1"
Cv	0.8	1.3	2.8	7.5	13.5
Flow Rate (GPM @ 60 psi)	4.6	6.3	10.7	23	42
Inlet Port Max. Pressure (psi)	60	60	60	60	60
Outlet Port Max. Pressure (psi)	60	50	50	30	20
Actuator Pressure (Min/Max)	40 / 60	40 / 60	40 / 60	50 / 70	50 / 70
Max. Media Temp. (PVDF)	240°F	240°F	240°F	240°F	240°F
Max. Ambient Temp.	140°F	140°F	140°F	140°F	140°F
Wetted Surfaces	PTFE	PTFE	PTFE	PTFE	PTFE
Actuator / Base / Bands	PVC, POL, PVDF	PVC, POL, PVDF	PVC, POL, PVDF	PVC, POL, PVDF	PVC, POL, PVDF
Actuator Port (see diagram)	10-32 UNF	1/8" FNPT	1/8" FNPT	1/8" FNPT	1/8" FNPT
Inlet Port (in) (FNPT Std)	1/4"	3/8"	1/2"	3/4"	1"
Outlet Port (in)	1/4"	3/8"	1/2"	3/4"	1"

Pressure listed for Distribution Flow Configuration.
Contact us for Selection Flow Configuration.

Ordering Format

CR - POL - 4W 8 P - O C C
0 1 2 3 4 5 6 7

0. Valve Series

CR = FNPT
CRT = Tube
CRF = Flare

1. Actuator Material

PVC = Polyvinyl Chloride
(ambient T = 140°F)
POL = Polypropylene
(ambient T = 160°F)
PVDF = Polyvinylidene Fluoride
(ambient T = 230°F)

2. Valve Configuration

2W = 2 Way
3W = 3 Way
4W = 4 Way

3. Size

4 = 1/4"
6 = 3/8"
8 = 1/2"
12 = 3/4"
16 = 1"

4. Outlet Port Connection

P = FNPT
T = Tube
F = Flare

5. Port 1

C = Normally Closed
O = Normally Open

6. Port 2

(Only for 2-way and 3-way config.)
C = Normally Closed
O = Normally Open

7. Port 3

(Only for 3-way config.)
C = Normally Closed
O = Normally Open

Contact us for 5-way to 14-way models.

Flow for distribution (One Inlet & Multiple Outlets) and flow for blending or selection (Multiple Inlets & One Outlet) available. Distribution flow is standard. Please specify at time of order.

Dimensions

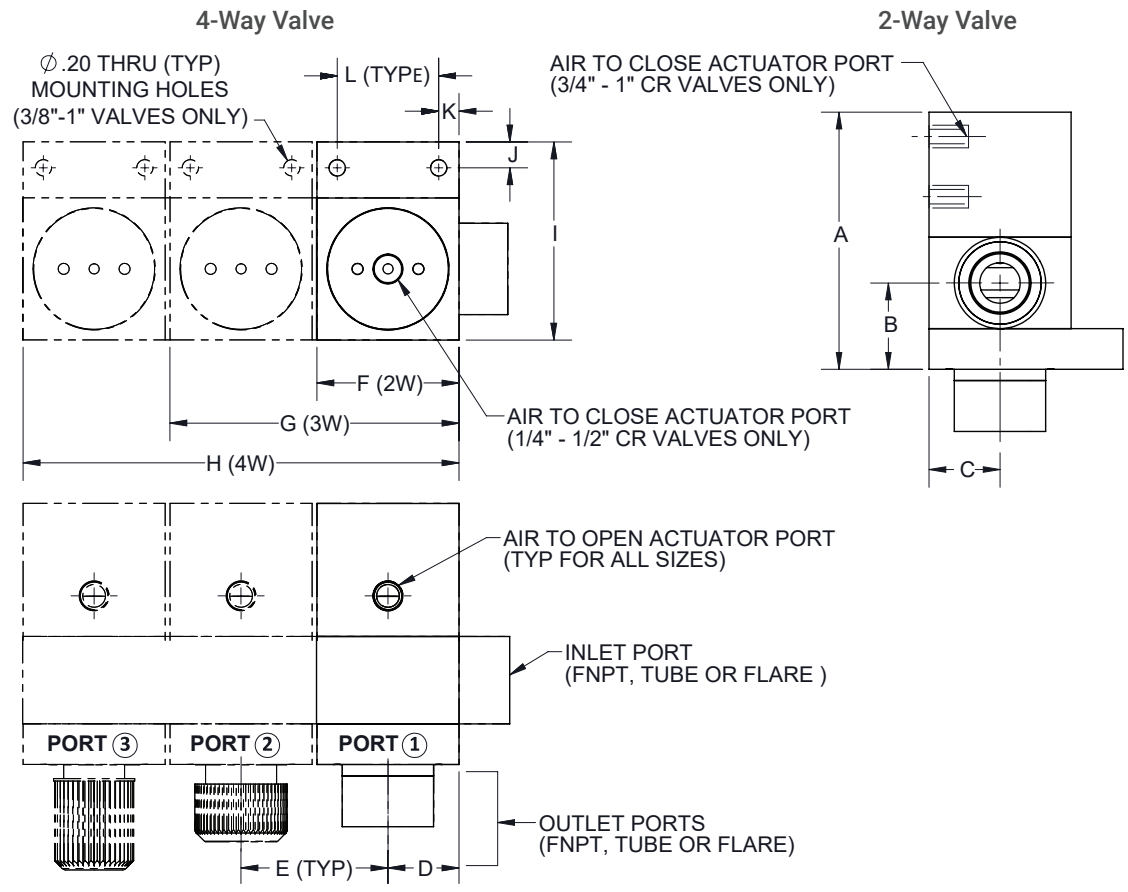

1/4" CR models come complete with aluminum baseplate.

3/8" - 1" CR models come with reinforcing bands & baseplates that match the selected actuator material (PVC, POL or PVDF).

CR Valve is supplied standard with a single axial manifold FNPT style port.

Size	A	B	C	D	E	F	G	H	I	J	K	L	M
1/4"	2.19	0.69	0.69	0.69	1.40	1.38	2.78	4.18	1.38	N/A	N/A	N/A	N/A
3/8" - 1/2"	3.31	1.06	0.88	0.88	1.81	1.75	3.56	5.37	2.44	0.32	0.25	1.25	0.20
3/4" - 1"	5.13	1.44	1.38	1.38	2.81	2.75	5.56	8.37	3.44	0.33	0.33	2.03	0.20

iPolymer | Inline Diaphragm Valves

Inline Diaphragm Valves

Our inline diaphragm valves feature an all-wetted PTFE flow path with a diaphragm design for ultra pure service. Common applications include DI Water, Acid Drain, and Source Chemistry flow shutoff.

- Two-way normally closed configuration
- All PTFE wetted flow path
- Long life diaphragm design
- Inline flow path reducing cavity corners & dead spots



Specifications

Part	Port (in)	End Connection
IDF-103233-001	1/2	FNPT
Size	1/2"	
Cv	2.8	
Max Pressure Inlet Port (psi)	60	
Max Pressure Outlet Port (psi)	40	
Actuator Pressure Range (psi)	60 / 80	
Max. Media Temperature	212°F	
Max. Ambient Temperature	140°F	
Wetted Surfaces	PTFE	
Pneumatic Surfaces	Polypropylene	
Inlet Port	1/2"	
Outlet Port	1/2"	
Actuator Port (FNPT)	1/8"	

Dimensions

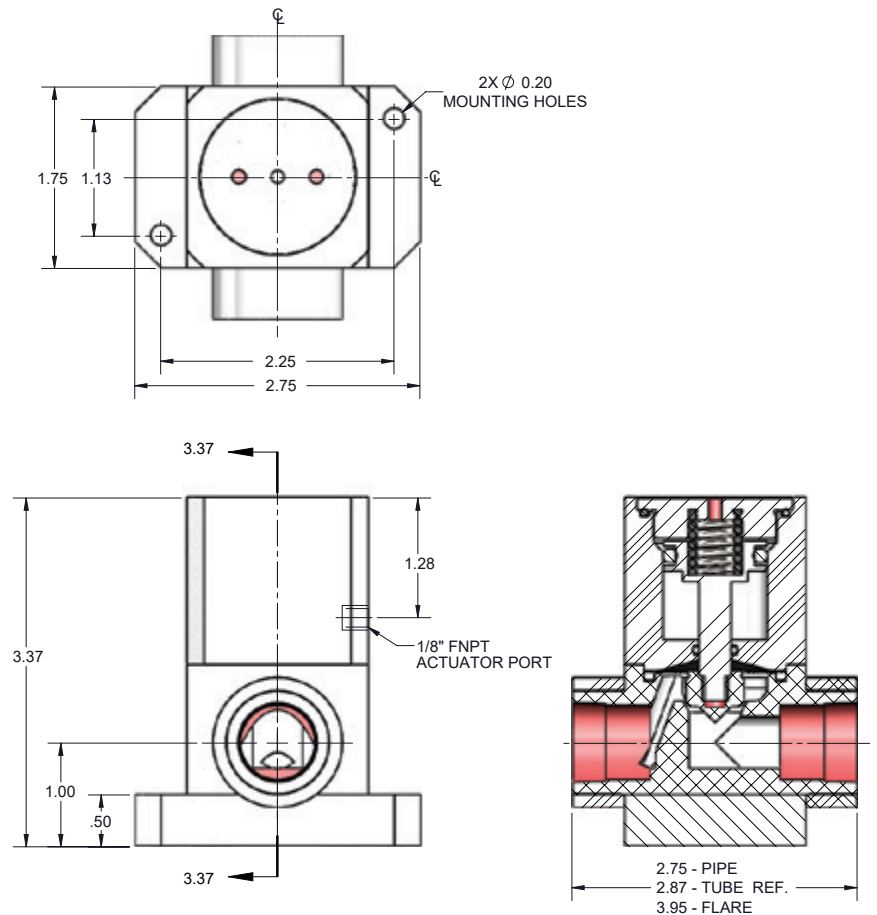

iPolymer Product Notes:

1. Please email Customer Service at info@ipolymer.com
2. Call us for special applications.
3. Alternate materials are available that may allow for expanding temperature ratings or other performance characteristics.
4. Unauthorized disassembly will void the original factory one-year product warranty. Contact us or your Distributor for details.

iPolymer | Suckback Valves

Suckback Valves

Suckback Valves are ideal for acid, solvent, photoresist solutions and other process dispensed chemistries. The iPolymer Suckback Valve will pull a vacuum and prevent excessive dripping from the dispensing nozzle.

The iPolymer Suckback Valve is constructed of an "all wetted" PTFE media flow path.

Our Suckback Valve incorporates the suckback feature in a Normally Closed pneumatic valve.

When air pressure is removed from the valve actuator, an internal diaphragm is pushed upward which forms a vacuum in the valve body.

While the valve is closing, the vacuum sucks back the final droplets of fluid. Thereafter, the valve completely closes and seals the media flow path.

An additional unique feature of the Suckback Valve is a Vacuum Adjustment Knob which allows the user to set the vacuum level.



Specifications

Part	Port (in)	End Connection
SBV-104168-4-F	1/4	FNPT
Actuator Pressure Range (psi)		45 / 60
Max. Media Pressure (psi)		30
Max. Media Temperature		176°F / 80°C
Max. Ambient Temperature		140°F / 60°C
Suckback Amount		0.25 - 0.50 cc @ Room Temp & S.G. = 1.0

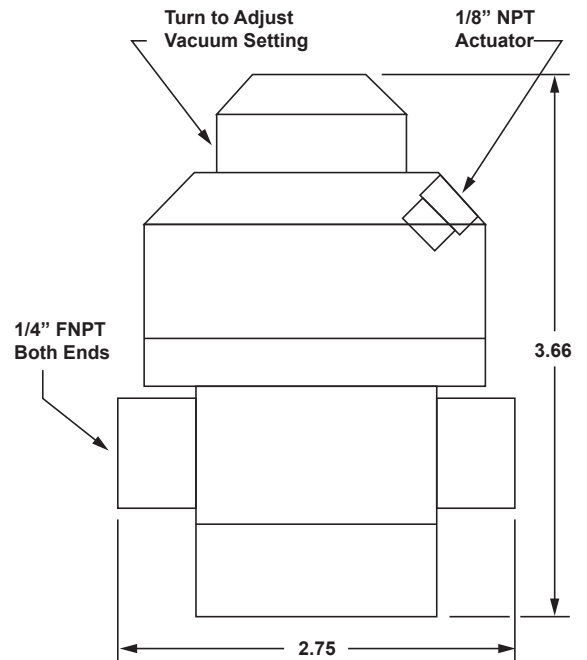

iPolymer Product Notes:

1. Please email Customer Service at info@ipolymer.com
2. Call us for special applications. We can manufacture our Valves with special mounting and interface dimensions.
3. Alternate materials are available that may allow for expanding temperature ratings or other performance characteristics.
4. Unauthorized disassembly will void the original factory one-year product warranty. Contact us or your Distributor for details.

iPolymer | DI Water Valve

DI Water Valve

iPolymer DI Water Valves are perfect 2-way valves for wet benches and chemical process facilities where ultrapure water is required. Wetted Path is free of lubricants, elastomers, and springs.

DI Valve materials of construction include three options for the Body, Piston and Cap Assembly: PVC, Polypropylene or PVDF. For the highest level of chemical inertness and overall fluid handling performance all three configurations include 100% Virgin PTFE for the Bellows and Backing Plate construction.

O-Ring Seal options include EP. All DI Valve come standard with high performance Stainless Steel actuation springs.



Specifications

Model	PVC	Polypro	PVDF
Valve Type	2-Way NO or NC	2-Way NO or NC	2-Way NO or NC
Port & Orifices Available	3/8", 1/2", 3/4" & 1"	3/8", 1/2", 3/4" & 1"	3/8", 1/2", 3/4" & 1"
Fluid Max Pressure (psi) @ 70°F	75	75	75
Media Backpressure (psi) @ 70°F	30	30	30
Fluid Temperature Range	32 - 140°F	32 - 160°F	32 - 212°F
Ambient Temperature Range	32 - 120°F	32 - 140°F	32 - 175°F
Actuation Pressure (psi)	40 - 80	40 - 80	40 - 80

Ordering Format

DI - PVC - 66 P - C - RC
 0 1 2 3 4 6

0. Valve Series

DI = DI Water Valves

1. Material of Construction

PVC = Polyvinyl Chloride

POL = Polypropylene

PVDF = Polyvinylidene Fluoride

2. Port & Orifice Size

66 = 3/8"

88 = 1/2"

1212 = 3/4"

1616 = 1"

3. End Connection

P = FNPT

4. Valve Configuration

C = Normally Closed

5. Optional Flow Path

(Only for NC Valves)

AB = Hand turn, Micro Adjust Knob

RC = Restricted Closed

DI valves are also known as

"MP" Multi-Purpose Valve.

Call for special configurations.

Dimensions

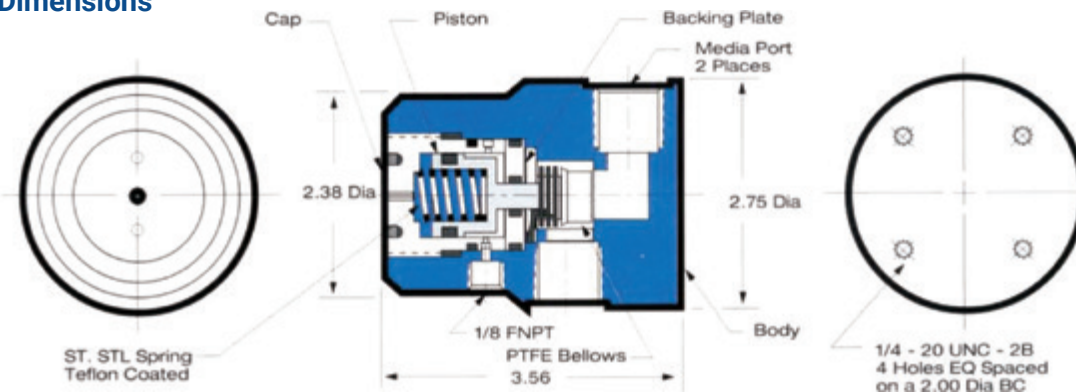

Port & Orifice	Cv	Dim A	Dim B	Dim C
3/8"	2.1	2.75	3.56	2.38
1/2"	2.8	2.75	3.56	2.38
3/4"	7.5	4.00	5.91	3.25
1"	13.5	4.00	5.91	3.25

iPolymer | Water Valve

Water Valve

iPolymer Water Valve is manufactured in Polypropylene. The valve has a spring return and is pneumatically actuated to open or close, depending upon the model. The valve is compact and comes with four tapped holes on the base for ease of mounting.

Applications

iPolymer Water Valve is primarily used for purified water, DI water, and controlled process tank applications. The Polypropylene configurations of this valve can be used for numerous mild chemical applications. These include rinsing, blending, and other pneumatically controlled process applications.

Specifications

Model (Orifice Size)	1/4"	1/2"	3/4"
Cv	0.8	2.8	7.5
Max Pressure Inlet (psi)	80	80	60
Max Media Temperature - Poly	140°F / 60°C	140°F / 60°C	140°F / 60°C
Max Media Temperature - PVDF	212°F / 100°C	212°F / 100°C	212°F / 100°C
Actuator Pressure Range	35 / 70	35 / 70	35 / 70

Dimensions

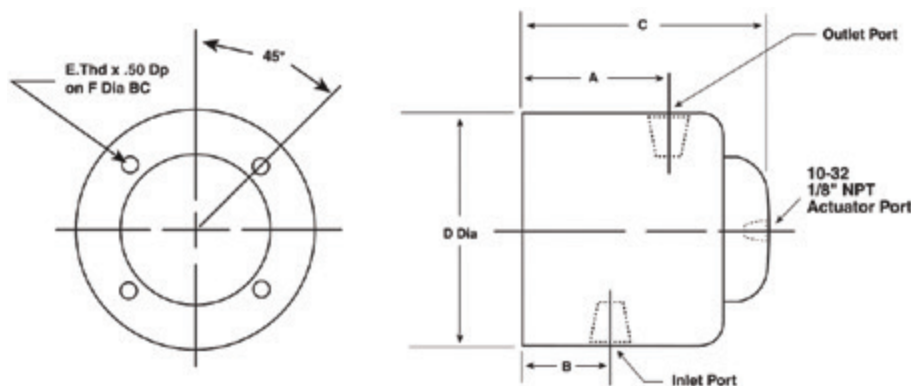

Model (Size)	A	B	C	D Dia	E Thd	F Dia
1/4"	1.52	1.00	2.44	2.25	1/4" - 20 UNC-2B	1.81
1/2"	1.69	.96	2.78	2.75	1/4" - 20 UNC-2B	2.00
3/4"	2.28	1.33	3.66	3.00	1/4" - 20 UNC-2B	2.50



Ordering Format

WV - POL - 44 P - NO - EP - AST
 0 1 2 3 4 5 6

0. Valve Series

WV = Water Valves

1. Material of Construction

POL = Polypropylene

2. Port & Orifice Size

44 = 1/4"
 88 = 1/2"
 1212 = 3/4"

3. End Connection

P = FNPT

4. Valve Configuration

NC = Normally Closed
 NO = Normally Open

5. O-Ring Type

EP = Ethylene Propylene
 VT = FKM (Viton Eq.)

6. Optional Flow Path

AST = Adjustment Screw Top-side
 ASB = Adjustment Screw Bottom-side
 ATB = Both AST and ASB

AST = Reduce bacterial buildup with an Adjustment Screw Top-side. The adjustment screw, installed at the top of valve, prevents complete closure thereby allowing a controlled drip. Ideal for DI Water applications. Only available to "NO" configurations.

ASB = Create a metering effect with an Adjustment Screw Bottom-side. The adjustment screw, installed at the bottom of the valve, meters the orifice opening. Only available to "NC" configurations.

ATB = Combine both optional features into one valve (AST + ASB) with Adjustment Screws Top-side & Bottom-side for both controlled drip and orifice metering. Only available to "NC" configurations.

iPolymer | Drain Valve

Drain Valve

iPolymer Drain Valves are large-orifice valves capable of handling large volumes of corrosive fluids via an all nonmetallic wetted surface. For cost efficiency this valve is fabricated from PVC or Polypropylene. However, it is available in PVDF or PTFE, with FKM (Viton Eq.) O-rings. This valve is also available in 2, 3 and 4 way configurations with each port operating independently. The "DV" can be operated either by air to open/air to close or by spring return. Either operating method can be specified in the ordering format. Custom configurations available.



Specifications

Inlet Media Pressure	20
Media Temperature - PVC	140°F/60°C
Media Temperature - Polypropylene	160°F/70°C
Media Temperature - PVDF	212°F/100°C
Media Temperature - PTFE	284°F/140°C (consult factory)
Actuation Pressure (psi)	45 - 60
O-Ring Material	FFKM (Kalrez® Eq.)

Applications

Primarily used for quick draining and filling of process tanks which contain mild solutions or DI water. For hard to handle media the "DV" valve, machined from PVDF or PTFE, is the perfect solution.

Ordering Format

DV - 2 - PVC - 16 - C - VT
 0 1 2 3 4 5

0. Valve Series
 DV = Drain Valves

1. Valve Configuration
 2 = 2-Way (1 actuator)
 3 = 3-Way (2 actuator)
 4 = 4-Way (3 actuator)

2. Material of Construction
 PVC = Polyvinyl Chloride
 POL = Polypropylene
 PVDF = Polyvinylidene Fluoride
 PTFE = Polytetrafluoroethylene

3. Port & Orifice Size
 12 = 3/4"
 16 = 1"
 24 = 1 1/2"
 32 = 2"

4. Porting Configuration
 C = Spring to Close, Air to Open
 O = Spring to Open, Air to Close
 A = Air to open, Air to Close

5. O-Ring Type
 VT = FKM (Viton Eq.)

4-WAY example:
 COA = (C=Port 1, O=Port 2, A=Port 3)
 shown upper left corner

3-WAY example:
 CO = (C=Port 1, O=Port 2)
 shown upper left corner

Dimensions

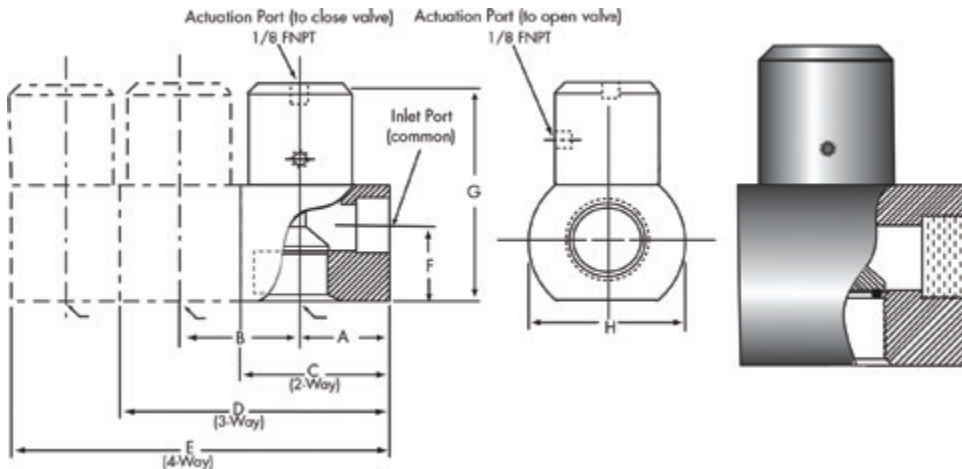

Port Size	A	B	C	D	E	F	G	H Dia
3/4"	2.16	2.56	3.50	6.07	8.63	1.88	5.43	4.00
1"	2.16	2.56	3.50	6.07	8.63	1.88	5.43	4.00
1-1/2"	2.31	3.07	3.88	6.88	9.88	1.97	5.97	4.00
2"	3.00	3.50	4.81	8.31	11.81	2.37	7.70	5.00

iPolymer | Quick Dump Valves

Quick Dump Valves

Our Quick Dump ("QD") Valves are designed to rapidly drain process tanks. Constructed from high-purity polymers, which are selected to meet your application needs, our Quick Dump Valves are available in Polypropylene (POL) or Polyvinylidene Fluoride (PVDF). These valves are designed to be welded directly to the underside (bottom) of tanks. Our Quick Dump Valves are available configured with either O-Ring Seats or Domed Hard Seats. The Domed Hard Seat design prevents ponding/puddling of media on the valve piston and allows for a slight trickle of fluid. This plunger-style valve is very compact, while still configured with optional Air-to-Open/Spring-to-Close or Air-to-Open/Air-to-Close actuation.



Specifications

Size	2"	4"
Actuation Pressure Range (psi)	60 / 70	45 / 55
Media Temperature Range - Polypropylene	30 - 140°F	30 - 140°F
Media Temperature Range - PVDF	20 - 212°F	20 - 212°F
Approximate Dump Rate (GPM @ 1ft Head)	30	60

Installation Instructions: At time of installation actuate valve at full actuation pressure and hold pressure while welding body in place.

Dimensions

Size (Dia)	Seat	Base	A	B	C	D
2"	O-Ring	104520	2"	3"	3.0"	.78"
2"	Hard	104521	2"	3"	3.0"	.78"
4"	O-Ring	103809	4"	5"	3.0"	.78"
4"	Hard	103952	4"	5"	3.0"	.78"
4" (high flow)	O-Ring	104602	4"	5"	4.0"	1.43"
4" (high flow)	Hard	104683	4"	5"	4.0"	1.43"

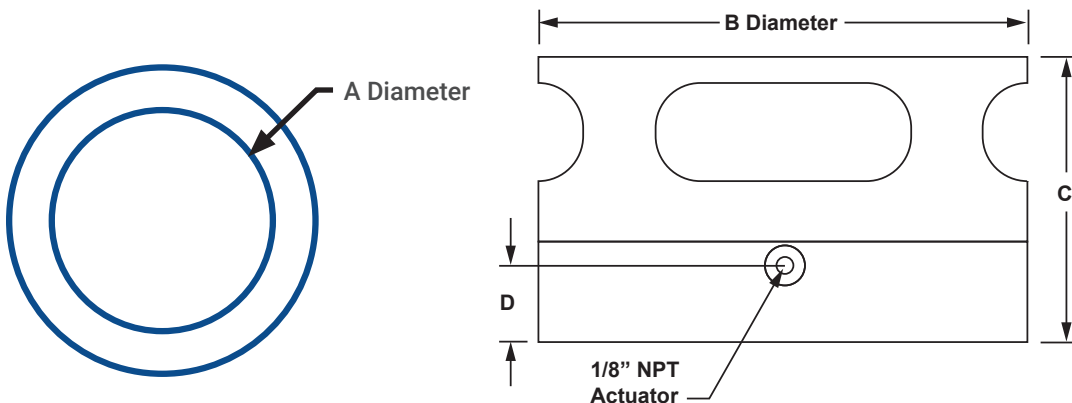

Ordering Format

QD - 103809 - POL - E - 1
 0 1 2 3 4

0. Valve Series

QD = Quick Dump Valves

1. Base Number (Dia. Size)

- 104520 = 2" O-Ring Seat
- 103809 = 4" O-Ring Seat
- 104602 = 4" High-Flow O-Ring Seat
- 104521 = 2" Hard Seat
- 103952 = 4" Hard Seat
- 104683 = 4" High-Flow Hard Seat

2. Material of Construction

- POL = Polypropylene
- PVDF = Polyvinylidene Fluoride

3. Body O-Ring Type

- E = EPDM
- V = FKM (Viton Eq.)

4. Configuration

- 1 = Air Open/Spring Close
- 2 = Air Open/Air Close

**O-ring Seat Material is same as Body O-Ring Type. Hard Seat Material is same as Material of Construction.*

iPolymer | Check Valves

Check Valves

Check Valve feature all PTFE wetted surfaces for excellent directional flow control in high-purity applications. Our PTFE design resists chemical corrosion and other elements within harsh process environments. They are commonly used as backflow preventers in clean processes. The special internal control spring for 3 psi to 6 psi (nominal 5 psi) cracking pressure is machined virgin PTFE.

Highlights

- PTFE wetted materials
- PFA or PVDF non-wetted materials
- 100 psi max. operating pressures
- 100°C max. temperatures

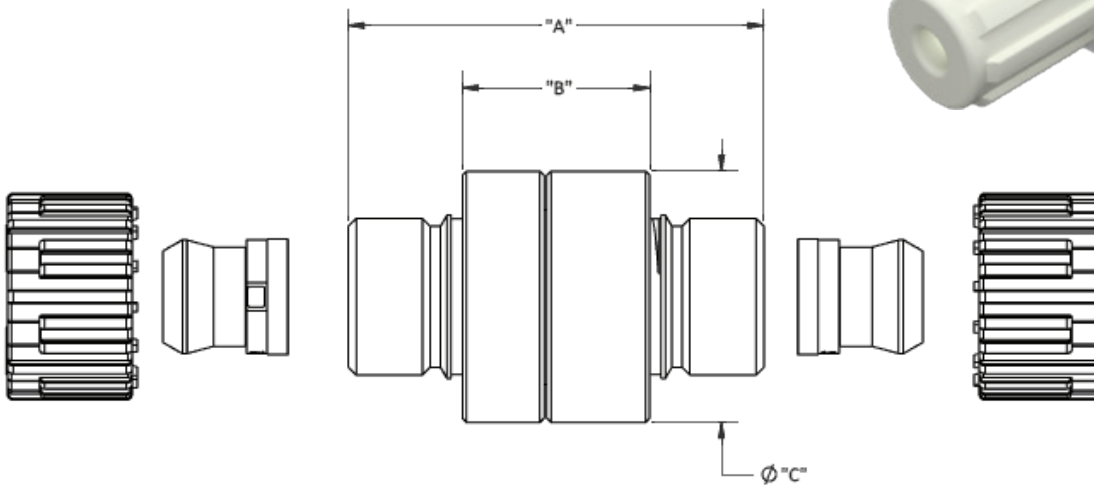
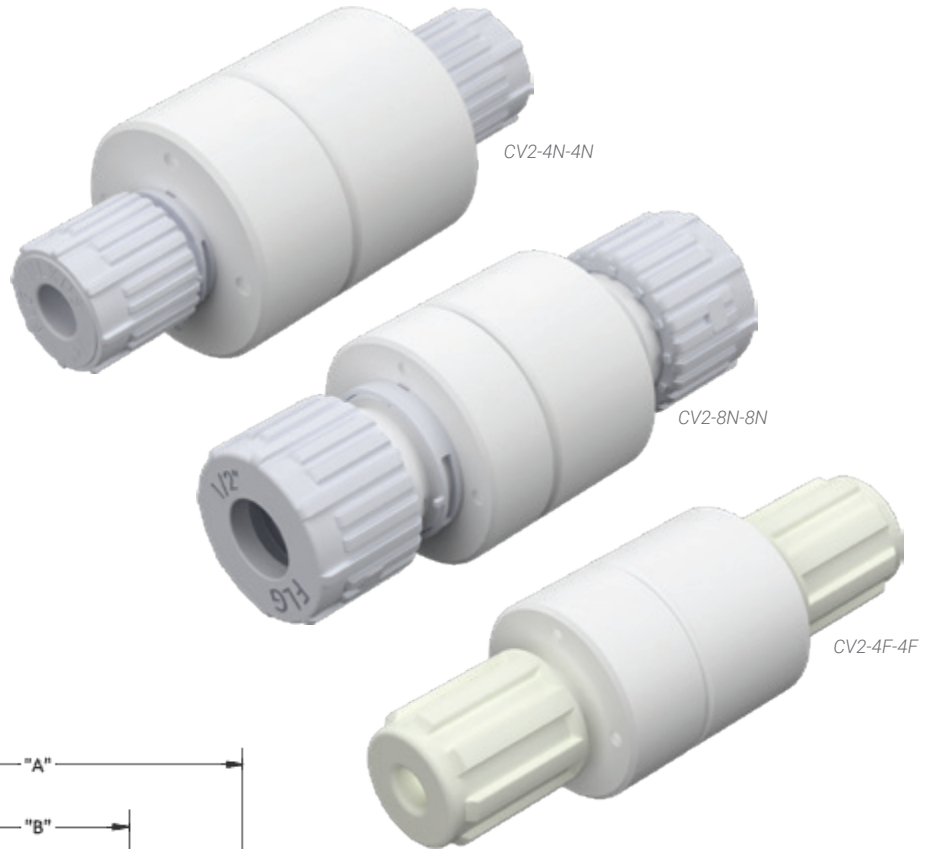

Specifications

Part	Port Size	Connection	Wetted Materials	Non-Wetted Materials	Opening Pressure	Back Pressure / Sealing Pressure	Operating Pressure	Operating Temperature	Dim A	Dim B	Dim C	Cv
CV2-4F-4F	1/4 in	Flaretek Compatible	PTFE	PVDF	<1 PSI	5 PSI	0-100 PSI	0-100°C	3.51	1.51	1.25	0.5
CV2-4N-4N	1/4 in	Nexus	PTFE	PFA	<1 PSI	5 PSI	0-100 PSI	0-100°C	2.37	1.51	1.25	0.5
CV2-6F-6F	3/8 in	Flaretek Compatible	PTFE	PVDF	<1 PSI	5 PSI	0-100 PSI	0-100°C	3.51	1.51	1.25	1.6
CV2-6N-6N	3/8 in	Nexus	PTFE	PFA	<1 PSI	5 PSI	0-100 PSI	0-100°C	2.69	1.51	1.25	1.6
CV2-8F-8F	1/2 in	Flaretek Compatible	PTFE	PVDF	<1 PSI	5 PSI	0-100 PSI	0-100°C	3.62	1.42	1.50	2.7
CV2-8N-8N	1/2 in	Nexus	PTFE	PFA	<1 PSI	5 PSI	0-100 PSI	0-100°C	2.80	1.42	1.50	2.7
CV2-12F-12F	3/4 in	Flaretek Compatible	PTFE	PVDF	<1 PSI	5 PSI	0-100 PSI	0-100°C	3.92	1.42	1.90	6.2
CV2-12N-12N	3/4 in	Nexus	PTFE	PFA	<1 PSI	5 PSI	0-100 PSI	0-100°C	3.15	1.42	1.90	6.2
CV2-16F-16F	1 in	Flaretek Compatible	PTFE	PVDF	<1 PSI	5 PSI	0-100 PSI	0-100°C	3.92	2.13	2.75	9.8
CV2-16N-16N	1 in	Nexus	PTFE	PFA	<1 PSI	5 PSI	0-100 PSI	0-100°C	4.26	2.13	2.75	9.8

Nexus connections are Pillar S-300 Compatible

iPolymer | Pressure Relief Valve

Pressure Relief Valve

Pressure Relief Valve (PRV) is constructed with a 100% pure PTFE valve body and valve plug, and an FFKM (Kalrez Eq.) O-ring. It is fully adjustable within its standard 10 - 90 psi pressure range. Simply adjust the upper Socket Hex Adjustment Screw and lock it in place with the associated locking nut to your desired setting. Pressure Relief Valve is configured with three Upper Housing and Lower Base Options Polyvinylidene Fluoride (PVDF) or Polypropylene (PP).



Highlights

- All-wetted high-purity flow path
- Ideal for harsh chemicals
- Fully adjustable within an 80 psi selected range
- PTFE-coated spring is isolated from media
- Low range specifications available (3 - 25 psi)

Applications

- Pump pressure relief
- Expansion container pressure relief
- Flow channel pressure relief
- Safety relief from water hammer
- System protection for individual low pressure component in circuit

Specifications

Ambient Temperature Range	
PVDF	0 - 100°C
PP	0 - 60°C
Media Temperature Range	
PVDF	0 - 100°C
PP	0 - 60°C

Contact us for custom needs.
Minimum quantities required.

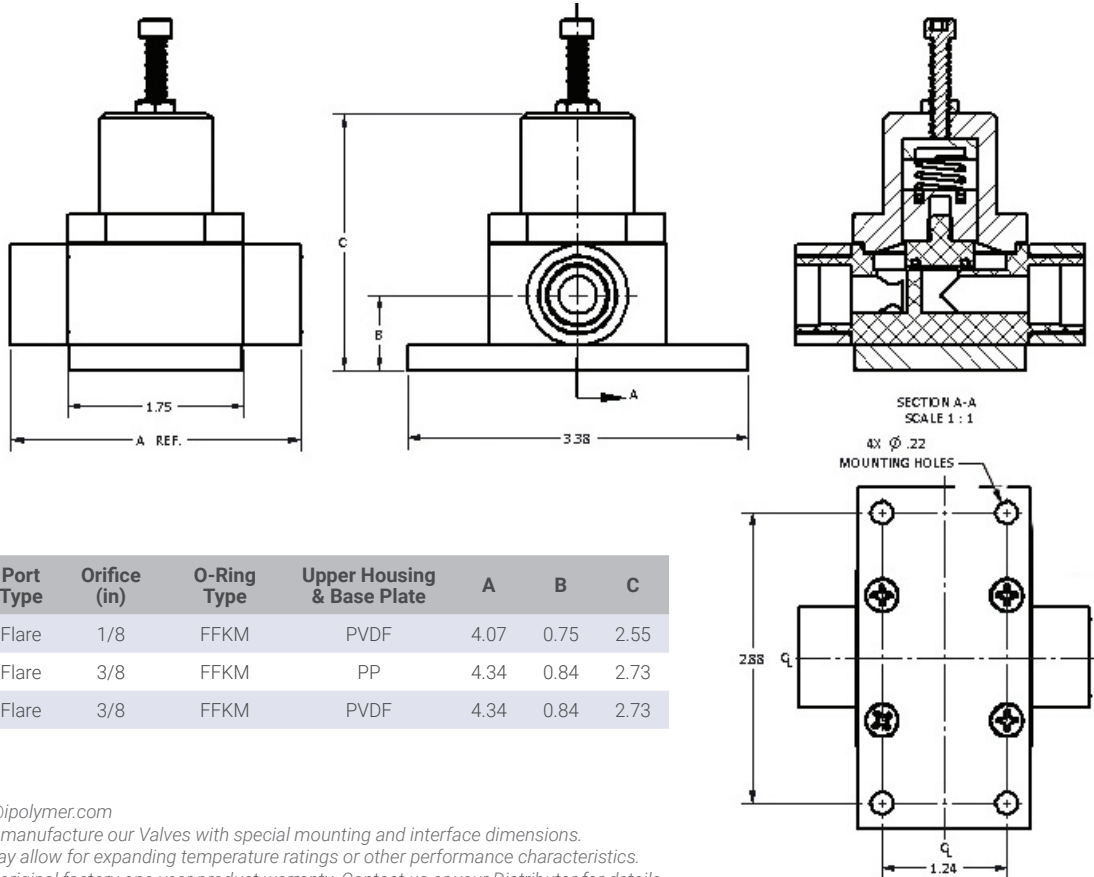

Part	Port Size (in)	Port Type	Orifice (in)	O-Ring Type	Upper Housing & Base Plate	A	B	C
PRV-42FF-KA-PVDF	1/4	Flare	1/8	FFKM	PVDF	4.07	0.75	2.55
PRV-86FF-KA-PP	1/2	Flare	3/8	FFKM	PP	4.34	0.84	2.73
PRV-86FF-KA-PVDF	1/2	Flare	3/8	FFKM	PVDF	4.34	0.84	2.73

iPolymer Product Notes:

1. Please email Customer Service at info@ipolymer.com
2. Call us for special applications. We can manufacture our Valves with special mounting and interface dimensions.
3. Alternate materials are available that may allow for expanding temperature ratings or other performance characteristics.
4. Unauthorized disassembly will void the original factory one-year product warranty. Contact us or your Distributor for details.

iPolymer | Miniature Solenoid Valves

Miniature Solenoid Valves

These valves offer precision performance under extreme conditions. Their virgin PTFE wetted surface designs provide unsurpassed chemical compatibility with a variety of flow media. Offered in 2-way and 3-way options with a PTFE hard seat or FKM (Viton eq.) O-ring, these valves are suitable for a variety of ultra-clean and highly corrosive media for semiconductor, pharmaceutical, biomedical and chemical process applications. The PTFE body, valve stem and one-piece diaphragm maintain a material inert boundary for ultra-clean applications.

Highlights

- PTFE design for ultra-clean and chemical compatibility
- Configurations available for various DC & AC voltages
- Continuous duty cycle rated at controlled ambient temperatures and reduced pressures
- Valve seat and diaphragm designed for positive flushing and bubble-tight shut off
- Non porous diaphragm configured to completely isolate solenoid coil from media
- 100% coil driven, which does not require energizing pressure or vacuum to operate
- O-ring seat configurations for vacuum and complex media applications
- Designed for aggressive media and elevated temperature

Recommendations

- Solenoid Valves are designed for Continuous Duty Cycles of 50% or less and for Energized Dwell Periods of no longer than 90 minutes.*
- For many applications, the Duty Cycle or Energized Dwell Period can be increased. Due to heat generation, without Power Management Circuit, it is not recommended to run with an accumulated Energized Dwell Period greater than 160 minutes per 8 hour production shift.*
- The Solenoid Coil on our valve generates heat when energized. Temperatures above 150°F will shorten coil life. Temperatures above 172°F are not recommended. Power Management Circuit will knock down the steady state temperature of a functioning coil.*
- Contact us for unique Solenoid Valve applications. Because of the heat generation, care must be taken to consider the ambient conditions and air flow around the coil of any solenoid valve application.*



Specifications

General Valve Parameters	
1/8 Orifice Cv (2W-NC, 2W-NO, 3W)	0.35 / 0.18 / 0.18
1/4 Orifice Cv (2W-NC, 2W-NO, 3W)	0.60 / 0.35 / 0.35
3/8 Orifice Cv (2W-NC, 2W-NO, 3W)	0.90 / 0.60 / 0.60
Common Port Vacuum in-Hg (max gauge)*	25 2-Way / 23 3-Way
Typical Response Time (msec)	20 - 30
Media Temperature (range)	0 - 80°C / 32 - 176°F
Ambient Temperature (range)	0 - 50°C / 32 - 122°F
Wattage Range (std)	11 - 13 W
Voltage Tolerance	-2% + 10%
Coil Lead Length (3 Wire) (Red is Hot / White is Neutral / Green is Ground)	24" - 22 gauge

Maximum Port Pressure Rating (psi)*	O-Ring Seat 3-Way	PTFE Seat 3-Way
Common Port	60	60
Normally Closed Port	35	30
Normally Open Port	60	60
	2-Way NC	2-Way NC
Inlet Port	60	60
Outlet Port	35	30
	2-Way NO	2-Way NO
Inlet Port	60	60
Outlet Port	60	60

*Referenced values based on opposing ports open to atmosphere. Vacuum Rating assumes O-Ring Seal and opposing ports open to atmosphere. Pressures listed are for solenoid valve operating at room temperature with coil temperatures elevated to a maximum of 120°F. Elevated coils temperature above 120°F result in reduce performance. Consult factory for performance under extreme conditions.

Ordering Format

M 66 2C 1A F S - H T - 123

0 1 2 3 4 5 6 7 8

0. Valve Series

M = Miniature Solenoid Valves

1. Ports / Max. Orifice

22 = 1/8" FNPT, 1/8" Orifice

44 = 1/4" FNPT, 1/4" Orifice

66 = 3/8" FNPT, 3/8" Orifice

42 = 1/4" Flare, 1/8" Orifice

2. Valve Configuration

2C = 2-Way Normally Closed

3W = 3 Way (See Port Arrangements)

3. Coil Voltage

1A = 115 VAC

2D = 24 VDC

4. Port Selection

F = Female NPT

FF = Flare

5. Body Shape

S = Square

6. Coil Wattage

H = Standard Coil

7. Valve Seat

V = FKM (Viton eq.)

T = PTFE Hard Seat

5. Port Arrangement

(Only for 3-way config.)

123 = NC-C-NO

132 = NO-C-NC

Top View of Coil

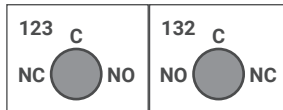

*Optional flyback diode available for use with sensitive controls. Contact us for custom configurations and vacuum applications.

Auxiliary Plate ("AP")

For highly corrosive or caustic gas applications, such as chlorine gas, our Auxiliary Plate option gives an extra line of protection. The valve has an auxiliary plate between the upper diaphragm and solenoid coil. The AP is O-ring sealed on the stem of the diaphragm and supported at the outer body-to-coil interface.



3/8" 3-Way FNPT



1/8" 2-Way FNPT



Dimensions

Typical Dimensions
for 3/8" and 1/2" Models

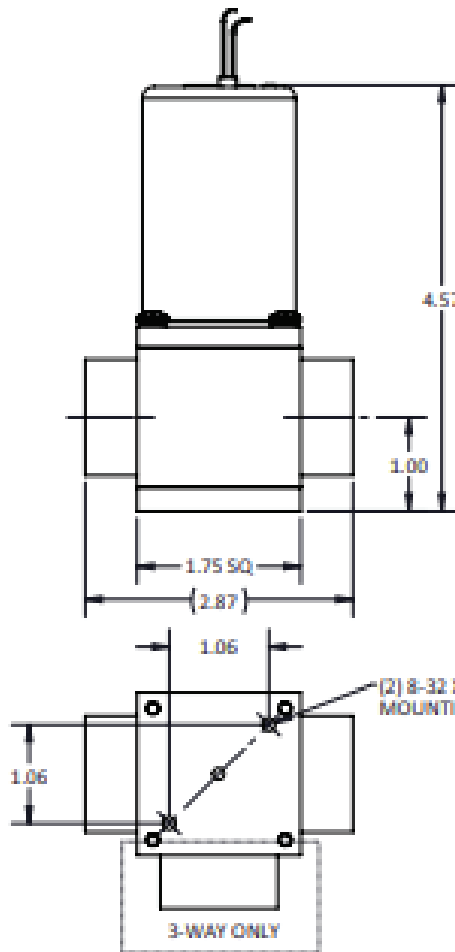

Typical Dimensions
for 1/8" and 1/4" Models

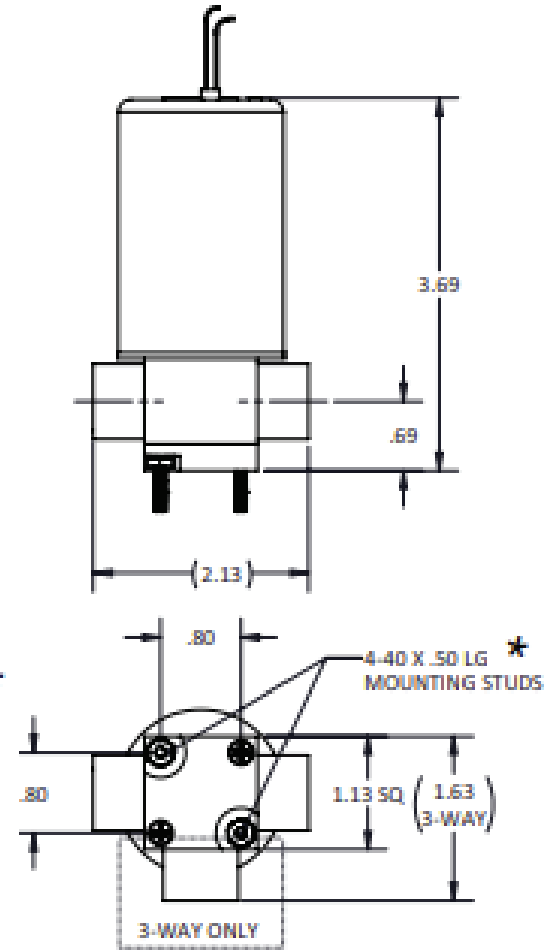

*Two Mounting Studs are supplied. Contact us for alternate mounting options. Limit applied torque on mounting studs to 7 - 9 in-lbs max.

iPolymer | Spray Guns

PTFE Spray Guns

iPolymer PTFE spray guns are quickly becoming the industry standard in semiconductor fab plants, wet benches and work processing stations. Models are available for rinsing, drying, ultraclean, and high-flow applications. Due to their design and comfortable grip Spray Guns are quickly becoming the industry standard in semiconductor fab plants, wet benches and work processing stations. A variety of hoses and fittings are available.

- 75 PSI Maximum pressure
- 40–130°F Temperature Range



PTFE Spray Rinsing Guns

SG Series spray guns are constructed of virgin PTFE and Polypropylene to provide excellent reliability and long life in harsh acidic or corrosive environments. They feature comfortable grips and offer a clean, even spray.



Nitrogen Drying Guns

Nitro Series PTFE Nitrogen spray guns can deliver maximum anti-corrosion protection wherever extreme chemical environments are used in the vicinity of nitrogen dispensing or drying. They are manufactured from PTFE and Polypropylene for reliability, longevity, and to resist acid attacks.

Recirculating Spray Guns

RC Series spray guns prevent stagnant water and eliminate bacterial growth in spray systems by minimizing empty spaces and continuously recirculating DI water. When the spray gun is not in use, the DI water flows down a parallel recirculation path back to a recovery tank or drain line. DI water is able to circulate up to the sealing seat throughout the entire gun and piston. They have molded PTFE bodies with PVDF pistons. From the sealing seat on, they feature a 1/16-in thick spray nozzle.

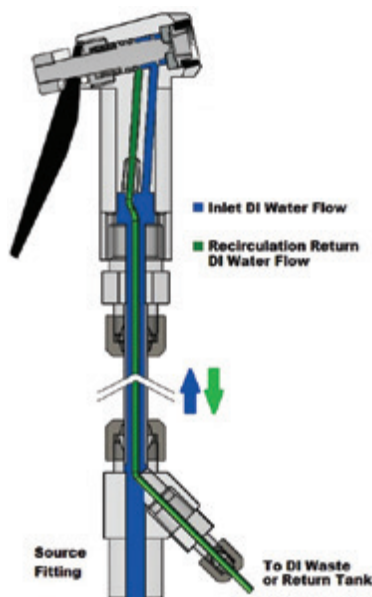

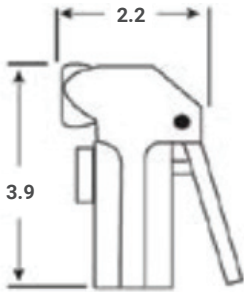

SG Series

Part	Description
SG-101	Spray gun with 1/4-in FNPT inlet
SG-102	Spray gun with 3/8-in FNPT inlet
SG-103	Spray gun with 1/2-in FNPT inlet

Special nozzle configurations available.

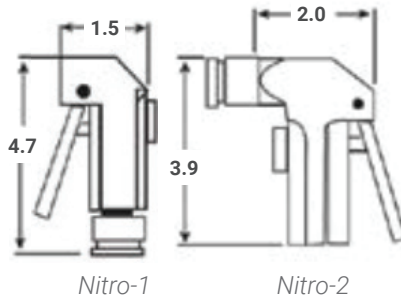

Nitro Series

Part	Description
NITRO-1	N2 spray gun with 1/4-in FNPT inlet, filter housing with disposable filter
NITRO-2	SG-101 with 1/4-in FNPT inlet, filter housing with disposable filter

Nitro guns are OSHA 1910.242(b) and 41-CFR-50-204.8 compliant with filter and housing attached.

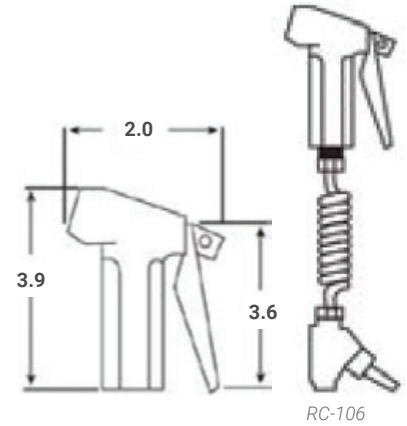

RC Series

Part	Description
RC-106	Recirculating gun with 1/2-in FNPT inlet thread, RC-5 Hose, and RC-9 PTFE fittings

*Components not available separately.

Hoses

Hose	Style	Material	OD (in)	Length (in)		Coil OD (in)	Compatible Guns
				Coiled	Stretch		
C4-FEP	Coiled	FEP	1/4	26	66	1-1/2	SG-101, NITRO-1, NITRO-2
C4-PU	Coiled	Blue PU	1/4	31	108	1-1/8	SG-101, NITRO-1, NITRO-2
C6-FEP	Coiled	FEP	3/8	26	66	2-3/8	SG-102
C6-PU	Coiled	Blue PU	3/8	34	108	2	SG-102
C8-FEP	Coiled	PFA	1/4	30	78	4	SG-101, NITRO-1, NITRO-2
C8-PU	Coiled	PFA	3/8	26	108	3-1/2	SG-102
304	Flexible	PTFE	1/4	96	n/a	n/a	SG-101
306	Flexible	PTFE	3/8	96	n/a	n/a	SG-102
308	Flexible	PTFE	1/2	96	n/a	n/a	SG-103
RC-5	Coiled	FEP	3/8	26	66	2-3/8	RC-106

*Ethylene propylene (EP), Fluorinated ethylene propylene (FEP), Kalrez (KA), Perfluoroalkoxy (PFA), Polytetrafluoroethylene (PTFE), Polyurethane (PU)

Fittings

Fitting	Description	Material	Compatible Guns
MC-F-44	iPolymer Male, 1/4-in Tube x 1/4-in MNPT	PTFE	SG-101, NITRO-1, NITRO-2
MC-F-66	iPolymer Male, 3/8-in Tube x 3/8-in MNPT	PTFE	SG-102
MC-F-88	iPolymer Male, 1/2-in Tube x 1/2-in MNPT	PTFE	SG-103
J44	JACO Male, 1/4-in Tube x 1/4-in MNPT	Polypro	SG-101, NITRO-1, NITRO-2
J66	JACO Male, 3/8-in Tube x 3/8-in MNPT	Polypro	SG-102
J88	JACO Male, 1/2-in Tube x 1/2-in MNPT	Polypro	SG-103
RC-9	Recirculation fitting	PTFE	RC-106

Disposable Nitrogen Filters

Part	Description
N2F-10 N2F-50 N2F-100	Disposable N2 Filters are used with Nitro Series guns. Each filter is composed of a 25mm diameter Hydrophilic Versapor® Acrylic Copolymer 800 Membrane 0.80um assembled with Polypropylene Ring with Clear Acrylic Luer Housing. Available in quantities of 10, 50, or 100.

iPolymer | Dilution Drain Valves

Dilution Drain Valves

Dilution Drain Valves are ideal for diluting and cooling liquid while draining it from a tank. They are designed to shut off the drain automatically if the water flow is interrupted. The DDV fits tanks with 3/8", 1/2" and 3/4" main drain ports.

Operation

When water pressure is activated, a unique spool valve design moves forward and aspirates the tank dry. When water pressure ends, a PTFE-coated, isolated-return spring automatically shuts off the valve.



Highlights

- PTFE wetted surfaces resist chemical corrosion and other harsh media
- Configured for easy facility hookup which only requires water pressure
- Water pressure range: 30 - 90 psi
- Fail-safe design will close the valve when dilution water is interrupted
- Main drain port is protected from chips and debris with a screened baffle plate
- Media operating temperature range is 32 - 212°F (0 - 100°C).

Note: High dilution rates will cause slow drain rates.

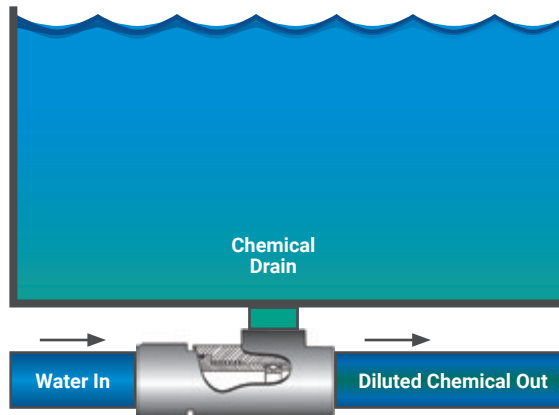

Ordering Format

DDV - 02 - 06 - V - T
0 1 2 3 4

0. Valve Series

DV = Dilution Drain Valve

1. Dilution Ratio

02 = 2:1

06 = 6:1

10 = 10:1

2. Main Drain & Inlet Port

06 = 3/8" FNPT

08 = 1/2" FNPT

12 = 3/4" FNPT

3. O-Ring Type

V = FKM (Viton Eq.)

K = FFKM (Kalrez Eq.)

4. Body Material

T = PTFE (std)

Main Drain Port matches Inlet Port.

Dimensions

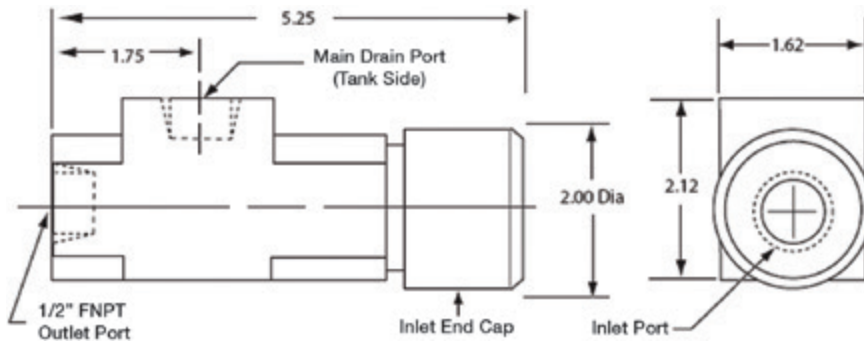

Performance

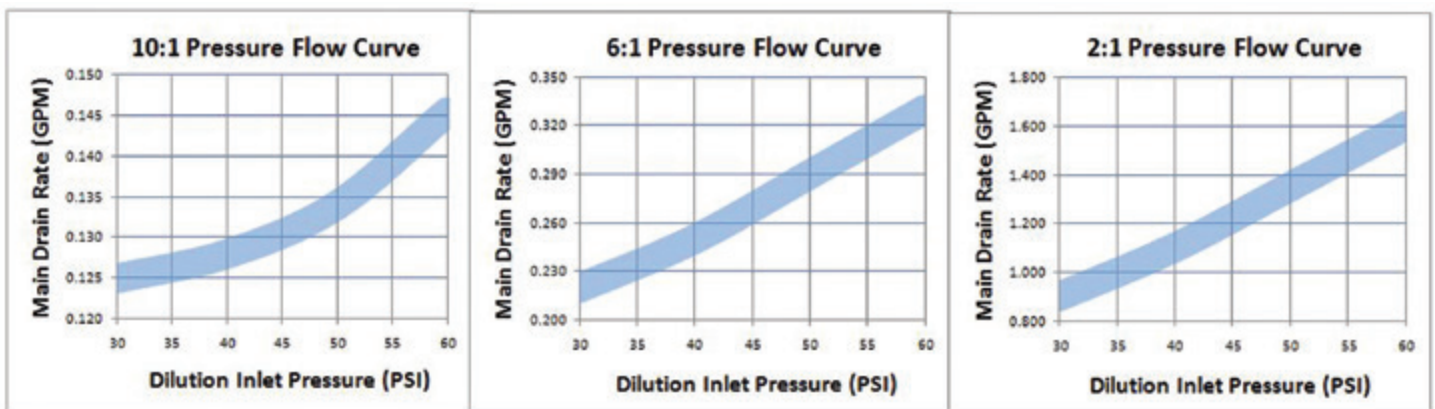

iPolymer | Aspirators

Aspirators

Air Aspirators use clean dry air (CDA) or Nitrogen to initiate and sustain a natural or forced siphon. Applications include the draining and mixing of containment vessels and the removal of saturated waste chemistry. Air Aspirators are also used where recovery recirculation is desired in process chemistries.

Liquid Aspirators use water or DI Water to aspirate and dilute harsh chemical baths. One common application is the dilution siphoning of Sulfuric Acid (H₂SO₄) used for chemical cleaning and etching.

PTFE Air and Liquid Aspirators are designed for efficient and rapid siphoning of harsh chemicals. They are essentially a low cost PTFE Venturi vacuum pump. They are sold as standalone siphoning bodies or as kits. Aspirator Kits include 8 feet of PTFE Tubing and Compression Fittings. The CHK Kit includes a special PTFE check valve mounted on the siphon port to prevent possible back flow.



Application

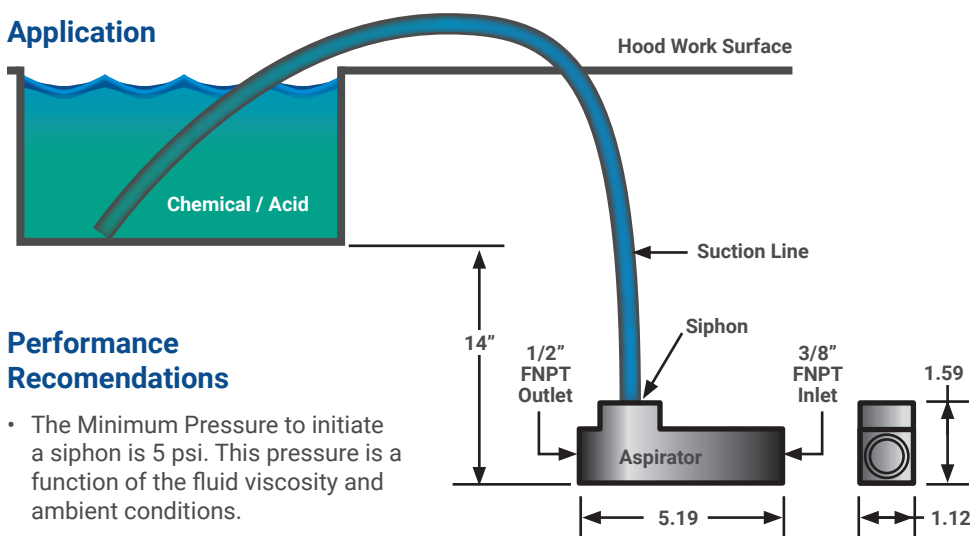

Performance Recommendations

- The Minimum Pressure to initiate a siphon is 5 psi. This pressure is a function of the fluid viscosity and ambient conditions.
- The 1/2" Aspirator will siphon with a slightly greater vacuum compared to the 3/8" Aspirator. Overall performance will vary based on the viscosity of the media being siphoned.
- Air Aspirators must be mounted at least 14" below the suction point (siphon point). Liquid Aspirators can be mounted level with the suction/ siphon point.
- For continuous flow applications, it is best to actuate an Air Aspirator with 30 to 50 psi of CDA for 10 to 15 seconds then turn off the air supply and allow the Air Aspirator to work by pure suction (siphoning action only).
- Back pressure on the Outlet Port will decrease the ability of the Aspirators to create a proper siphon.

Specifications

Pressure Rating	10 - 60 psi
Ambient Temperature Range	32 - 140°F (0 - 60°C)
Media Temperature Range	32 - 212°F (0 - 100°C)

Inlet Pressure	Air 3/8" Suction	Air 1/2" Suction	Liq. 3/8" Suction	Liq. 1/2" Suction
50 psi	6.3	7.2	13.0	13.3
40 psi	5.3	5.8	11.3	11.5
30 psi	4.0	4.5	8.9	8.9
20 psi	3.0	3.0	6.4	6.5
10 psi	1.5	1.5	3.8	3.8

Ordering Format

XX - A - 18 X 6 - XX - XXX
0 1 2 3

0. Aspirator Type

A = Air (aspirator body only)
 KA = Air Kit (see description below)
 L = Liquid (aspirator body only)
 KL = Liquid Kit (see description below)

1. Siphon Port Size (FNPT)

6 = 3/8" Siphon with a 3/8" Inlet & 1/2" Outlet
 8 = 1/2" Siphon with a 3/8" Inlet & 1/2" Outlet

2. Optional Dilution Orifice Plate at Siphon Port

02 = (2 - 3): 1 Dilution Orifice
 05 = (4 - 6): 1 Dilution Orifice
 10 = (8-12): 1 Dilution Orifice

3. Optional Check Valve

CHK = Kit with Check Valve

Dilution Ratios are approximate. Results will vary with fluid viscosity, temperatures, orientation of the Liquid Aspirator device. The addition of an orifice plate decreases the siphoning rate.

Aspirator Kits:

- Standard Kit:** Aspirator Body, Handle, 8 ft of PTFE Tubing and a PTFE Compression fittings for each port – Inlet, Outlet, and Siphon Ports.
- Check Valve Kit:** Aspirator Body, Handle, 8 ft of PTFE Tubing, PTFE Compression fittings for Inlet and Outlet, and PTFE Check Valve mounted on Siphon Port.

Part	Description
AH-1	Handle - 3/8" Suction Port
AH-2	Handle - 1/2" Suction Port

iPolymer | Air Cylinders

Air Cylinders

Air Cylinders are used where splash-back or fumes from highly aggressive chemicals are prime concerns. These Polypropylene or PVDF cylinders provide strength, durability and reliability in severe service actuation applications near corrosive chemicals.

Air cylinders are available in strokes from 1–16 inches and have standard easy-to-use mounting and optional position sensors. Our Air Cylinders are design to drive: 90 lbf | 400 N | 40.8 kg.

The weight an Air Cylinder can push and pull depends on the orientation, sliding surface friction, gravity, desired speed, travel distance, available air pressure, the pneumatic circuit design, and other factors.

Specifications

Cylinder Bore	1-1/4"
Port Connections	1/8 FNPT
Min. Actuation Pressure (psi)	20
Max. Actuation Pressure (psi)	80
Max. Ambient Temperature	
- Polypropylene	160° F / 70° C
- PVDF	212° F / 100° C
O-Rings Material	FKM (Viton Eq.)
Rod Style Thru Hole (in)	1/8

Ordering

Part	Materials	Stroke (in)
AC-POL-1VTVTA	Natural Polypro	1
AC-POL-2VTVTA	Natural Polypro	2
AC-POL-3VTVTA	Natural Polypro	3
AC-POL-4VTVTA	Natural Polypro	4
AC-POL-5VTVTA	Natural Polypro	5
AC-POL-6VTVTA	Natural Polypro	6
AC-POL-7VTVTA	Natural Polypro	7
AC-POL-8VTVTA	Natural Polypro	8
AC-POL-9VTVTA	Natural Polypro	9
AC-POL-10VTVTA	Natural Polypro	10
AC-POL-11VTVTA	Natural Polypro	11
AC-POL-12VTVTA	Natural Polypro	12
AC-POL-16VTVTA	Natural Polypro	16
AC-POL-15VTVTA	Natural Polypro	15
AC-PVDF-08VTVTA	PVDF	8

Lengths >7 inches require minimum order quantities.
Clevis bracket with stainless steel screws available.

Applications

- Remotely actuate doors, drawers
- Actuate drains and vents
- Repositioning of process loads



Performance

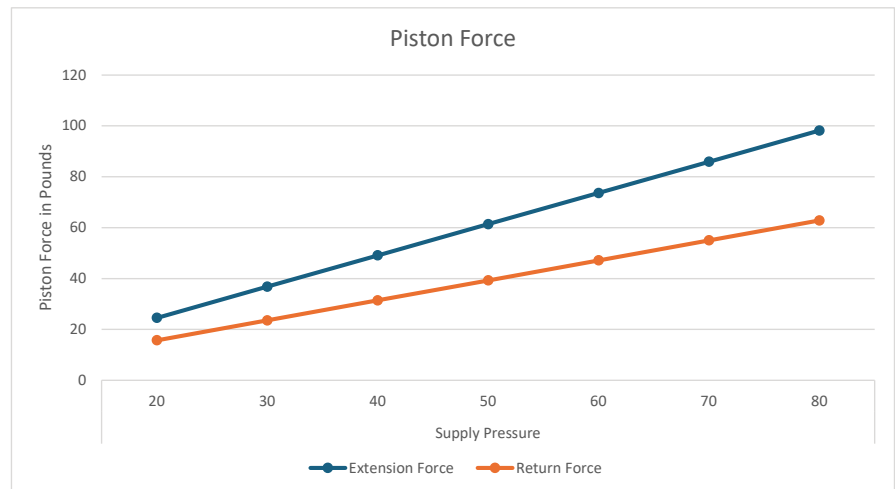

*Some efficiency loss is associated with exhaust rate and friction loss due to O-ring drag expected. Design systems accordingly with minimum 10X safety margin.

Dimensions

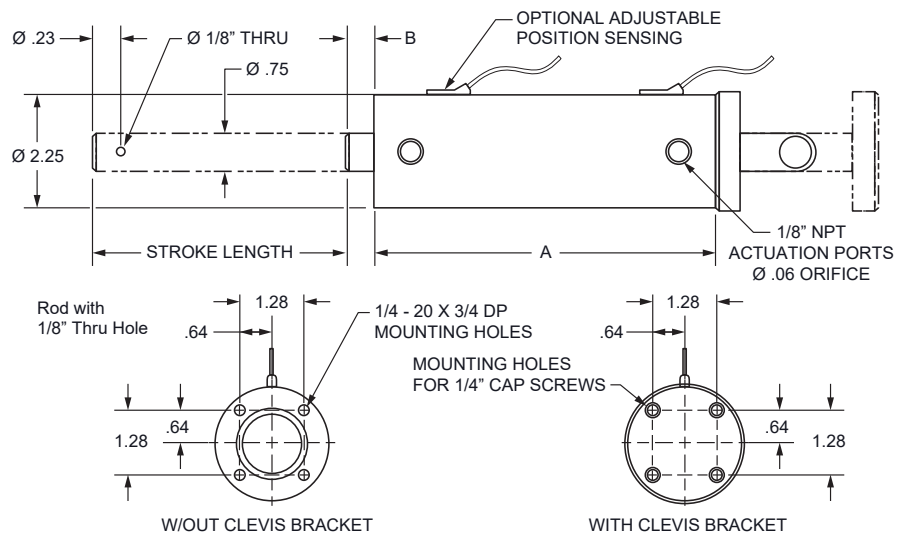

iPolymer | Gauge Isolator

Gauge Isolator

PTFE Body Gauge Isolator protects a pressure gauge or other pressure sensor from corrosive media and prevents contamination of ultrapure liquids. Gauge Isolators consist of a PTFE body with a close-tolerance machined cavity and a FEP diaphragm. The upper portion of the cavity is filled with a solution, such as glycerin, silicone or DI water.

Media pressure applied to the bottom side of the FEP diaphragm is transmitted through the solution filled cavity to the gauge, providing accurate readings while isolating the gauge from the media. Gauge fluctuation is minimized by the combination of the diaphragm design and the solution filling the upper portion of the Gauge Isolator.

Highlights

- PTFE and FEP wetted parts
- Chemically Inert
- Corrosion-resistant
- Supplied with or without gauge
- Highly sensitive
- User specified upper body material

Specifications

Sensitivity	6.9 kPa	1 psi (2" Hg)
Diaphragm Displacement	0.5 ml	0.02 oz
Internal Fill Volume	4.0 ml	0.14 oz
Ambient Temperature (for Glycerin & DI Water fill)	4°C to 93°C	40°F to 200°F
Ambient Temperature (for Silicon & Glycol)	-10°C to 110°C	15°F to 230°F
Max. Media Temperature	-30°C to 160°C	-22°F to 320°F
Max. Operating Pressure (see installed gauge for rating)	6.9 bar	100 psi

Dimensions

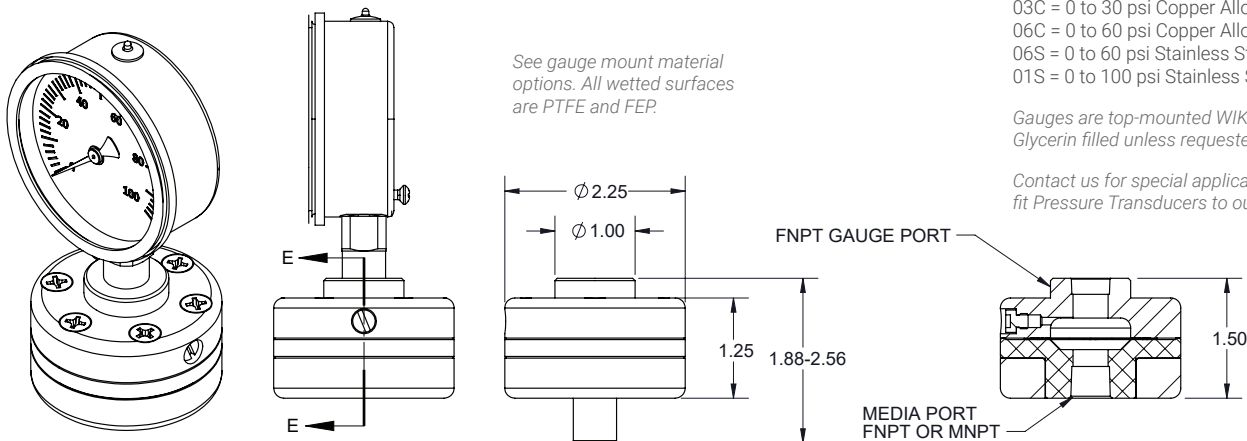

iPolymer Product Notes:

1. Please email Customer Service at info@ipolymer.com
2. Call us for special applications. We can manufacture our Gauge Isolators with special mounting and interface dimensions.
3. Alternate materials are available that may allow for expanding temperature ratings or other performance characteristics.
4. Unauthorized disassembly will void the original factory one-year product warranty. Contact us or your Distributor for details.



Ordering Format

GI - POL - 44 - DI - 100
0 1 2 3 4

0. Gauge Isolator Model

GI = PTFE Body Gauge Isolator

1. Gauge Mounting

(All Wetted surfaces are PTFE and FEP)

POL = Polypropylene

PVDF = Polyvinylidene fluoride

TFM = Dyneon-1600 Enhanced PTFE

2. Gauge Port & Mounting Orifice

44 = 1/4" FNPT Media and Gauge Port

42 = 1/4" FNPT Media Port, 1/8" FNPT Gauge Port

22 = 1/8" FNPT Media and Gauge Port

4M4 = 1/4" MNPT Media Port, 1/4" FNPT Gauge Port

3. Fluid Designator

Only add if ordering gauge.

G = Glycerin

DI = DI Water

4. Gauge Type

Only add if ordering gauge.

03C = 0 to 30 psi Copper Alloy (113.13)

06C = 0 to 60 psi Copper Alloy (612.20)

06S = 0 to 60 psi Stainless Steel (131.11)

01S = 0 to 100 psi Stainless Steel (232.30)

Gauges are top-mounted WIKA brand and Glycerin filled unless requested otherwise.

Contact us for special applications. We custom fit Pressure Transducers to our Gauge Isolator.

iPolymer | Fittings & Connectors

Fittings & Connectors

iPolymer offers an extensive line of PTFE fittings, including Flare, Compression, NPT, Flange, Barbed and more. All of our fittings are machined from 100% virgin PTFE. iPolymer's PTFE Flare fittings feature Fit-Line Global™ PVDF Flare Nuts that can be used with Fit-Line's TruFASTEN™ torque wrenches. iPolymer can also custom manufacture fittings to your exact sizing and configuration requirements with an exceptionally quick turn-around time.

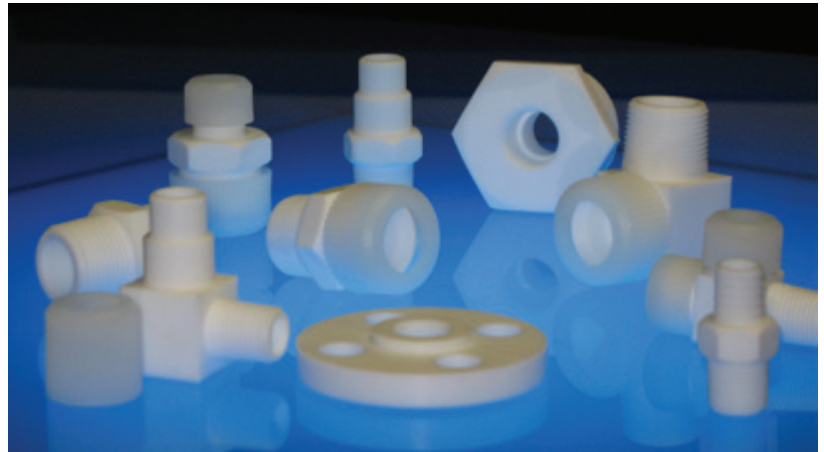

Fitting Materials

- Fittings are available in PTFE, PFA, or PVDF
- Tube fittings and ferrules are machined PTFE
- Two-piece ferrule-gripper assemblies are PVDF
- HA - Injection molded PVDF compression nuts
(Standard Config. Includes PTFE ferrule & Kynar Gripper)

Port Orifice Reference

Free flowing orifices through fittings and valve ports are defined by the standard port connection callout.

Female NPT (FNPT) & Male NPT (MNPT) ports flow with a maximum orifice equal to the Port Size callout.

Compression Tube and Flared connections have smaller flow orifices. See table below.

Port Size	Pipe Port (in)	Tube Port (in)	Flare Port (in)
1/16"	0.062	0.031	-
1/8"	0.125	0.063	-
1/4"	0.250	0.188	0.125
3/8"	0.375	0.312	0.250
1/2"	0.500	0.436	0.375
3/4"	0.750	0.688	0.592
1"	1.000	0.938	0.875

**Smaller orifices available.*

Fitting Types & Uses

Pipe: National Pipe Thread (NPT) threads are tapered at a rate of 1/16" per inch. The threads should be treated with joint compound or Teflon tape. These connections are commonly used for low-pressure gas and liquids.



Flared: Flared connections offer long term reliability and high pressure sealing. Mission critical connection. Considered an ultra-clean connection. Requires field flaring of tube with special tool after mating nut is installed.



Compression Tube: This fitting accepts straight tube with ferrule & nut (with/without gripper). Tube fittings are the most common connection for plastic applications. They accommodate fast assembly. Nut can include an integral gripper or external gripper.

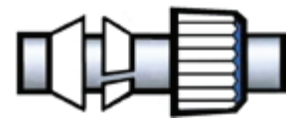

Barbed: Low-pressure fitting to mate with hose and tube connections. Angled barbs grab the ID of the hose or tube. Fast, reusable connection. Not intended for corrosive fluids and gases.



PTFE / Teflon® Tape

PTFE or Teflon® Tape is recommended for all NPT connections. When wrapped around pipe threads, the tape helps reduce thread damage, particularly when connecting PTFE to metal. Do not overtighten or strip threaded PTFE connections.



**Contact us with your special application requirements.
We manufacture custom machined PTFE and PVDF Fittings.**

Ordering Format

*Barbed & Bugle Fittings ordering format differs.

MC - F - 8 6

Connection Size

Tube OD, FNPT, MNPT, or Flared ID

Example: 6 = 6/16" (3/8"), OD

6 = 6mm Tube OD

6 = 3/8 Flared ID

Tube OD or Flare OD is Listed Before NPT Size

Fitting Category

F = Fractional Size Tube Fitting

M = Metric Size Tube Fitting

P = Pipe Fitting

FF = Fractional Flared

Fitting Type

Example: MC = Male Connector

Fractional size to connect 1/2" O.D Tubing to 3/8" MNPT, PVDF Nut

Ferrule & Gripper Style

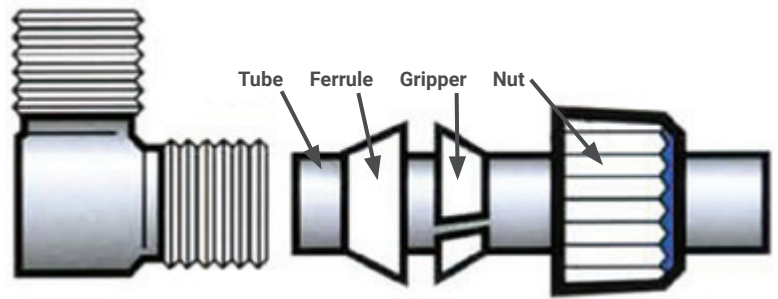

1. Cut tubing to desired length
2. Loosen nut and insert tube
3. Tighten nut finger tight
4. Fitting is ready for use

Flared End Style

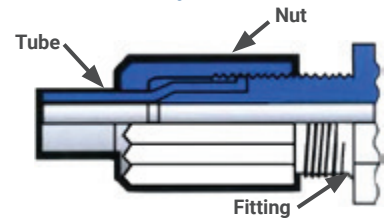

Pressure Rating Notes

- Temperatures at or below 22°C (72°F): 120 psi for 1/16" fittings linear decreasing to 80 psi for 3/4" fittings and 60 psi for fittings larger than 3/4"
- Temperatures elevated from 22°C (72°F) to 85°C (185°F): 90 psi for 1/16" fittings linear decreasing to 60 psi for 3/4" fittings and 40 psi for fittings larger than 3/4"
- Contact us for use above 85°C / 185°F

Pressure ratings are based on laboratory testing, material characteristics, and historical data. Extreme temperature or pressure may affect performance. Users are responsible for verifying the suitability of products for their application.

Pressure vs Temperature

PTFE FNPT & MNPT Fittings & Connectors & Schedule 80 Pipe

Curves represent working pressure versus media temperature (at soaked steady state) for standard PTFE, FNPT & MNPT fittings, connection, & Schedule 80 Pipe.

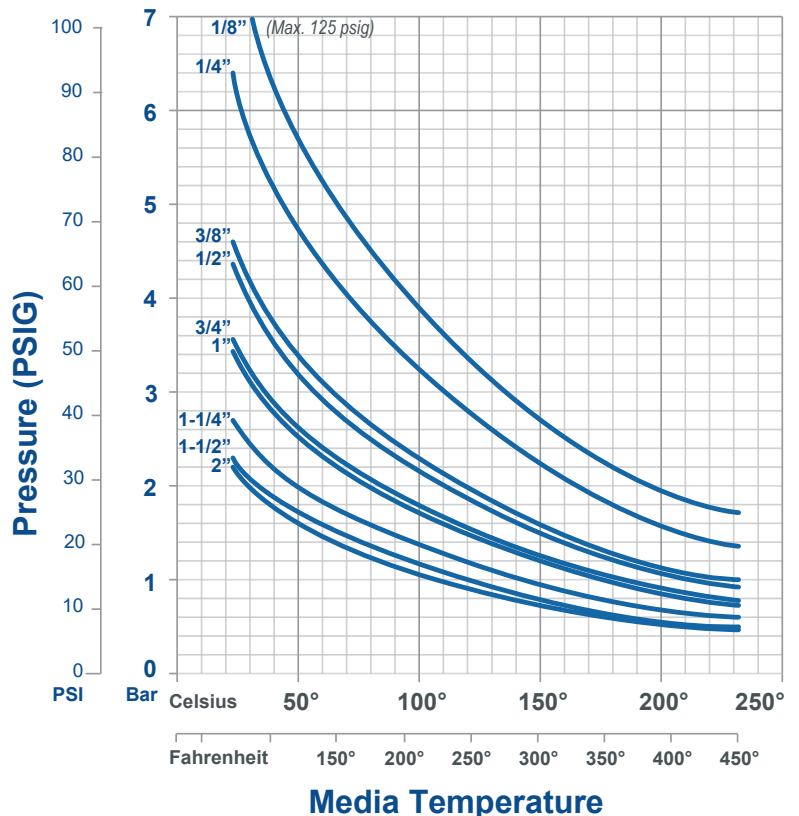

iPolymer Product Notes:

1. Please email Customer Service at info@ipolymer.com
2. Call us for special applications. We can manufacture our Fittings with special mounting and interface dimensions.
3. Alternate materials are available that may allow for expanding temperature ratings or other performance characteristics.
4. Unauthorized disassembly will void the original factory one-year product warranty. For further details please contact us or your local Distributor.

iPolymer | Tube Fittings

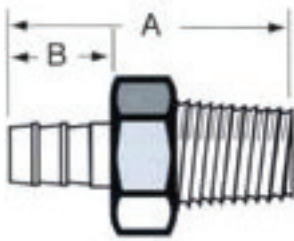

Barbed Fitting 101660

Part	Hose ID	MNPT	A Dim	B Dim
BF-F-34	3/16"	1/4"	1.44	.50
BF-F-36	3/16"	3/8"	1.44	.50
BF-F-74	7/16"	3/8"	1.69	.75
BF-F-76	7/16"	3/8"	1.69	.75
BF-F-78	7/16"	1/2"	2.00	.75

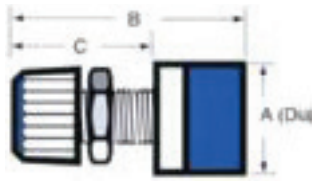

Bulkhead Female Connector 101772

Part	Tube OD	FNPT	Panel Hole	A Dim	B Dim	C Dim
BFC-F-22	1/8"	1/8"	21/64	.75	1.51	.88
BFC-F-42	1/4"	1/8"	29/64	.75	1.70	.94
BFC-F-44	1/4"	1/4"	29/64	.84	1.88	.94
BFC-F-88	1/2"	1/2"	57/64	1.25	2.44	1.19
BFC-M-42	4mm	1/8"	25/64	.75	1.38	.75
BFC-M-84	8mm	1/4"	37/64	.84	1.88	.94

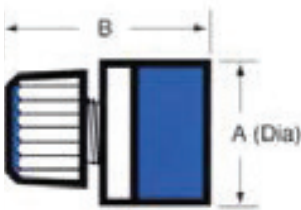

Female Connector 101619

Part	Tube OD	FNPT	A Dim	B Dim
FC-F-22	1/8"	1/8"	.75	1.14
FC-F-24	1/8"	1/4"	.84	1.32
FC-F-42	1/4"	1/8"	.75	1.26
FC-F-44	1/4"	1/4"	.84	1.44
FC-F-46	1/4"	3/8"	1.00	1.44
FC-F-66	3/8"	3/8"	1.00	1.44
FC-F-84	1/2"	1/4"	.875	1.62
FC-F-86	1/2"	3/8"	1.00	1.62
FC-F-88	1/2"	1/2"	1.25	1.81
FC-F-124	3/4"	1/4"	1.13	1.68
FC-F-128	3/4"	1/2"	1.13	1.87
FC-F-1212	3/4"	3/4"	1.50	1.87
FC-F-1616	1"	1"	1.75	2.14
FC-M-42	4mm	1/8"	.75	1.14
FC-M-62	6mm	1/8"	.75	1.26
FC-M-64	6mm	1/4"	.84	1.44
FC-M-84	8mm	1/4"	.84	1.44
FC-M-104	10mm	1/4"	.84	1.44
FC-M-106	10mm	3/8"	1.00	1.44
FC-M-128	12mm	1/2"	1.25	1.81

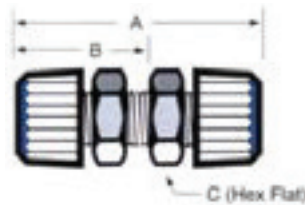

Bulkhead Union 101004

Part	Tube OD	Panel Hole	A Dim	B Dim	C Dim
BU-F-2	1/8"	21/64	1.51	.88	.44
BU-F-3	3/16"	25/64	1.51	.88	.44
BU-F-4	1/4"	29/64	1.81	.94	.56
BU-F-5	5/16"	37/64	1.81	.94	.75
BU-F-6	3/8"	45/64	1.81	.94	.75
BU-F-8	1/2"	57/64	2.25	1.19	.94
BU-F-10	5/8"	1-1/64	2.33	1.23	1.13
BU-F-12	3/4"	1-9/64	2.38	1.25	1.13
BU-F-16	1"	1-25/64	2.53	1.33	1.50
BU-M-4	4mm	25/64	1.51	.88	.44
BU-M-6	6mm	29/64	1.81	.94	.56
BU-M-8	8mm	37/64	1.81	.94	.75
BU-M-12	12mm	57/64	2.25	1.19	.94

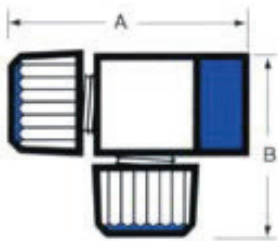

Female Run Tee 101003

Part	Tube OD	FNPT	A Dim	B Dim
FRT-F-22	1/8"	1/8"	1.39	1.01
FRT-F-86	1/2"	3/8"	2.13	1.56

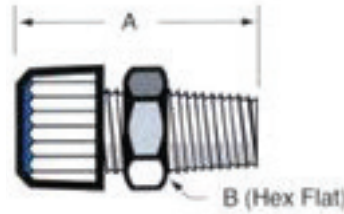

Male Connector 101008

Part	Tube OD	MNPT	A Dim	B Dim
MC-F-12	1/16"	1/8"	1.01	.44
MC-F-21	1/8"	1/16"	1.01	.44
MC-F-22	1/8"	1/8"	1.01	.44
MC-F-24	1/8"	1/4"	1.32	.56
MC-F-32	3/16"	1/8"	1.01	.44
MC-F-42	1/4"	1/8"	1.26	.56
MC-F-44	1/4"	1/4"	1.44	.56
MC-F-46	1/4"	3/8"	1.44	.75
MC-F-48	1/4"	1/2"	1.75	.94
MC-F-52	5/16"	1/8"	1.26	.75
MC-F-54	5/16"	1/4"	1.44	.75
MC-F-56	5/16"	3/8"	1.44	.75
MC-F-64	3/8"	1/4"	1.56	.75
MC-F-66	3/8"	3/8"	1.56	.75
MC-F-68	3/8"	1/2"	1.75	.94
MC-F-84	1/2"	1/4"	1.62	.94
MC-F-86	1/2"	3/8"	1.62	.94
MC-F-88	1/2"	1/2"	1.81	.94
MC-F-108	5/8"	1/2"	1.85	1.13
MC-F-1212	3/4"	3/4"	1.87	1.25
MC-F-1612	1"	3/4"	1.95	1.50
MC-F-1616	1"	1"	2.14	1.50
MC-M-42	4mm	1/8"	1.01	.44
MC-M-62	6mm	1/8"	1.26	.56
MC-M-64	6mm	1/4"	1.44	.56
MC-M-84	8mm	1/4"	1.44	.75
MC-M-104	10mm	1/4"	1.44	.75
MC-M-106	10mm	3/8"	1.44	.75
MC-M-126	12mm	3/8"	1.62	.94
MC-M-128	12mm	1/2"	1.81	.94

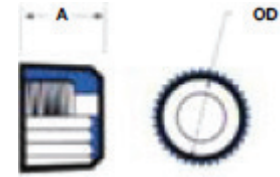

Tube Nut 101966 111722 103202

Part	Tube OD	Thread	A Dim	B Dim
N-F-1	1/16"	1/4-28	.61	.50
N-F-2	1/8"	5/16-24	.61	.50
N-F-3	3/16"	3/8-24	.61	.59
N-F-4	1/4"	7/16-20	.61	.68
N-F-5	5/16"	9/16-18	.64	.78
N-F-6	3/8"	1-1/16-16	.64	.88
N-F-8	1/2"	7/8-14	.73	1.25
N-F-10	5/8"	1-12	.77	1.38
N-F-12	3/4"	1-1/8-12	.82	1.50
N-F-16	.1"	1-3/8-12	.90	1.75
N-M-4	4mm	3/8-24	.61	.59
N-M-6	6mm	7/16-20	.61	.66
N-M-8	8mm	9/16-18	.64	.88
N-M-10	10mm	11/16-16	.64	.91
N-M-12	12mm	7/8-14	.73	1.16

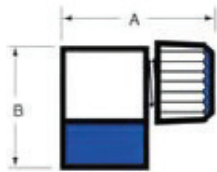

Female Elbow 101611

Part	Tube OD	FNPT	A Dim	B Dim
FE-F-22	1/8"	1/8"	1.01	1.01
FE-F-42	1/4"	1/8"	1.13	1.13
FE-F-44	1/4"	1/4"	1.31	1.31
FE-F-64	3/8"	1/4"	1.31	1.31
FE-F-66	3/8"	3/8"	1.44	1.44
FE-F-68	3/8"	1/2"	1.88	1.88
FE-F-86	1/2"	3/8"	1.56	1.56
FE-F-88	1/2"	1/2"	1.88	1.88
FE-F-108	5/8"	1/2"	1.88	1.88
FE-F-128	3/4"	1/2"	2.00	2.00

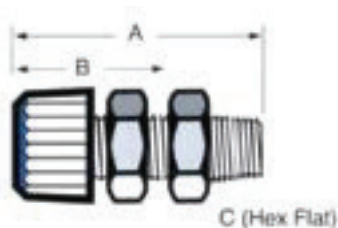

Bulkhead Male Connector 101788

Part	Tube OD	MNPT	Panel Hole	A Dim	B Dim	C Dim
BMC-F-42	1/4"	1/8"	29/64	1.57	.94	.56

*For 1/4" max. panel thickness

*Bore-Through ("BT") option is available for Male Connectors #101008 and Unions #101616, which allows the tube to pass completely through the fitting.

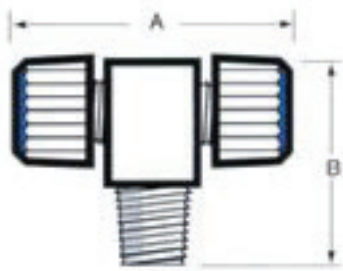

Male Branch Tee 101613

Part	Tube OD	MNPT	A Dim	B Dim
MBT-F-22	1/8"	1/8"	1.20	1.01
MBT-F-24	1/8"	1/4"	1.32	1.31
MBT-F-42	1/4"	1/8"	1.56	1.13
MBT-F-44	1/4"	1/4"	1.56	1.13
MBT-F-64	3/8"	1/4"	1.75	1.50
MBT-F-68	3/8"	1/2"	2.00	1.94
MBT-F-88	1/2"	1/2"	2.12	1.94
MBT-M-42	4mm	1/8"	1.20	1.01
MBT-M-62	6mm	1/8"	1.56	1.13
MBT-M-64	6mm	1/4"	1.56	1.31
MBT-M-84	8mm	1/4"	1.75	1.50

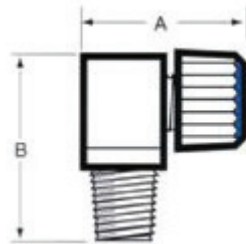

Male Elbow 101006

Part	Tube OD	MNPT	A Dim	B Dim
ME-F-22	1/8"	1/8"	.82	1.01
ME-F-24	1/8"	1/4"	1.06	1.31
ME-F-32	3/16"	1/8"	.82	1.01
ME-F-42	1/4"	1/8"	1.06	1.14
ME-F-44	1/4"	1/4"	1.06	1.31
ME-F-46	1/4"	3/8"	1.25	1.50
ME-F-54	5/16"	1/4"	1.25	1.44
ME-F-62	3/8"	1/8"	1.25	1.31
ME-F-64	3/8"	1/4"	1.25	1.50
ME-F-66	3/8"	3/8"	1.25	1.50
ME-F-68	3/8"	1/2"	1.56	1.94
ME-F-86	1/2"	3/8"	1.56	1.94
ME-F-88	1/2"	1/2"	1.56	2.06
ME-F-1212	3/4"	3/4"	1.88	2.31
ME-F-1616	1"	1"	2.20	2.75
ME-M-42	4mm	1/8"	.82	1.01
ME-M-62	6mm	1/8"	1.06	1.31
ME-M-64	6mm	1/4"	1.06	1.31
ME-M-84	8mm	1/4"	1.25	1.44
ME-M-104	10mm	1/4"	1.25	1.50
ME-M-106	10mm	3/8"	1.25	1.50

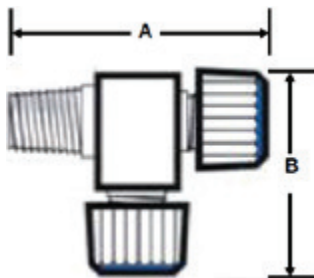

Male Run Tee 101195

Part	Tube OD	MNPT	A Dim	B Dim
MRT-F-42	1/4"	1/8"	1.63	1.06
MRT-F-44	1/4"	1/4"	1.81	1.06
MRT-F-64	3/8"	1/4"	2.00	1.25
MRT-F-66	3/8"	3/8"	2.00	1.25
MRT-F-86	1/2"	3/8"	2.31	1.56

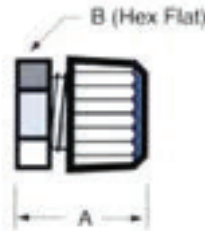

Tube Cap 101875

Part	Tube OD	A Dim	B Dim
TC-F-2	1/8"	.63	.44
TC-F-4	1/4"	.88	.56
TC-F-8	1/2"	1.06	1.00
TC-F-12	3/4"	1.12	1.25

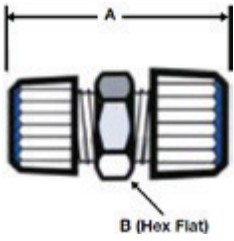

Reducing Union 101620

Part	Tube OD	Tube OD	A Dim	B Dim
RU-F-32	3/16"	1/8"	1.01	.44
RU-F-42	1/4"	1/8"	1.26	.56
RU-F-43	1/4"	3/16"	1.26	.56
RU-F-52	5/16"	1/8"	1.26	.75
RU-F-54	5/16"	1/4"	1.38	.75
RU-F-64	3/8"	1/4"	1.38	.75
RU-F-84	1/2"	1/4"	1.56	.94
RU-F-86	1/2"	3/8"	1.56	.94
RU-F-104	5/8"	1/4"	1.60	1.13
RU-F-106	5/8"	3/8"	1.60	1.13
RU-F-108	5/8"	1/2"	1.66	1.13
RU-F-128	3/4"	1/2"	1.68	1.25
RU-F-1210	3/4"	5/8"	1.72	1.25
RU-F-168	1"	1/2"	1.76	1.50
RU-F-1610	1"	5/8"	1.80	1.50
RU-F-1612	1"	3/4"	1.82	1.50
RU-M-46	4mm	6mm	1.26	.56
RU-M-68	6mm	8mm	1.38	.75
RU-M-610	6mm	10mm	1.38	.75
RU-M-810	8mm	10mm	1.38	.75
RU-M-812	8mm	12mm	1.56	.94
RU-M-1012	10mm	12mm	1.56	.94

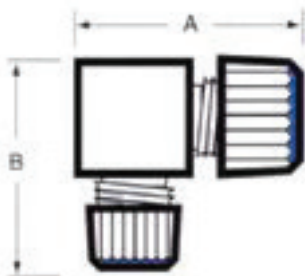

Union Elbow Reducer 101787

Part	Tube OD	Tube OD	A Dim	B Dim
UER-F-42	1/4"	1/8"	1.06	1.06
UER-F-64	3/8"	1/4"	1.25	1.25
UER-F-84	1/2"	1/4"	1.56	1.56
UER-F-86	1/2"	3/8"	1.56	1.56
UER-M-84	8mm	4mm	1.25	1.25

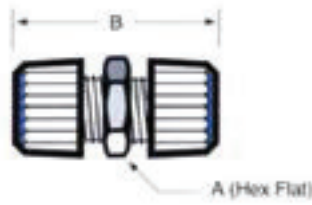

Union 101616

Part	Tube OD	A Dim	B Dim
U-F-2	1/8"	.44	1.01
U-F-4	1/4"	.56	1.38
U-F-6	3/8"	.75	1.38
U-F-8	1/2"	1.00	1.62
U-F-10	5/8"	1.13	1.70
U-F-12	3/4"	1.25	1.74
U-F-16	1"	1.50	1.90
U-M-4	4mm	.44	1.01
U-M-6	6mm	.56	1.38
U-M-8	8mm	.75	1.38
U-M-10	10mm	.75	1.38
U-M-12	12mm	1.00	1.62

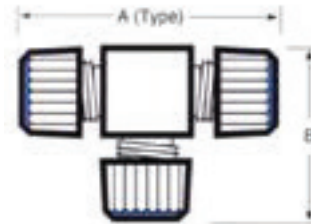

Union Tee 101005

Part	Tube OD	A Dim	B Dim
UT-F-2	1/8"	1.20	.82
UT-F-4	1/4"	1.56	1.06
UT-F-6	3/8"	1.75	1.25
UT-F-8	1/2"	2.12	1.56
UT-F-10	5/8"	2.33	1.73
UT-F-12	3/4"	2.50	1.89
UT-F-16	1"	2.90	2.20
UT-M-4	4mm	1.20	.82
UT-M-6	6mm	1.56	1.06
UT-M-8	8mm	1.75	1.25
UT-M-10	10mm	1.75	1.25
UT-M-12	12mm	2.12	1.56

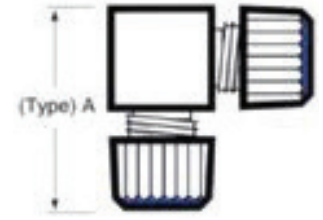

Union Elbow 100870

Part	Tube OD	A Dim
UE-F-2	1/8"	.82
UE-F-4	1/4"	1.06
UE-F-6	3/8"	1.25
UE-F-8	1/2"	1.56
UE-F-10	5/8"	1.73
UE-F-12	3/4"	1.87
UE-F-16	1"	2.20
UE-M-4	4mm	.82
UE-M-6	6mm	1.06
UE-M-8	8mm	1.25
UE-M-10	10mm	1.25
UE-M-12	12mm	1.56

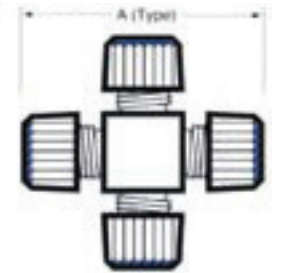

Union Cross 101610

Part	Tube OD	A Dim
UC-F-2	1/8"	1.20
UC-F-4	1/4"	1.56
UC-F-6	3/8"	1.75
UC-F-8	1/2"	2.12
UC-F-12	3/4"	2.49
UC-M-4	4mm	1.20
UC-M-6	6mm	1.56
UC-M-8	8mm	1.75
UC-M-12	12mm	2.12

iPolymer | Flare Fittings

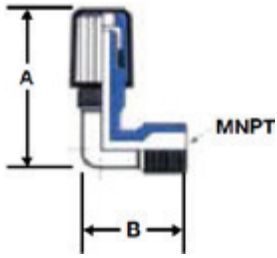

Male Elbow 104590

Part	Flare	MNPT	Orifice	A Dim	B Dim
ME-FF-42	1/4"	1/8"	1/8"	1.56	.95
ME-FF-44	1/4"	1/4"	1/8"	1.56	1.13
ME-FF-46	1/4"	3/8"	1/8"	1.56	1.13
ME-FF-64	3/8"	1/4"	1/4"	1.75	1.31
ME-FF-66	3/8"	3/8"	1/4"	1.75	1.31
ME-FF-68	3/8"	1/2"	1/4"	2.10	1.56
ME-FF-86	1/2"	3/8"	3/8"	2.10	1.56
ME-FF-88	1/2"	1/2"	3/8"	2.10	1.75
ME-FF-812	1/2"	3/4"	3/8"	2.35	2.00
ME-FF-128	3/4"	1/2"	5/8"	2.50	2.00
ME-FF-1212	3/4"	3/4"	5/8"	2.50	2.00
ME-FF-1216	3/4"	1"	5/8"	2.60	2.29

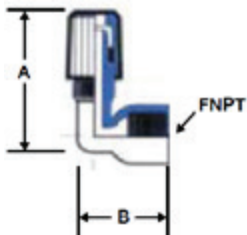

Female Elbow 108639

Part	Flare	FNPT	Orifice	A Dim	B Dim
FE-FF-42	1/4"	1/8"	1/8"	1.75	1.13
FE-FF-44	1/4"	1/4"	1/8"	1.88	1.44
FE-FF-46	1/4"	3/8"	1/8"	2.00	1.56
FE-FF-64	3/8"	1/4"	1/4"	1.88	1.44
FE-FF-66	3/8"	3/8"	1/4"	2.00	1.56
FE-FF-68	3/8"	1/2"	1/4"	2.25	2.00
FE-FF-86	1/2"	3/8"	3/8"	2.10	1.56
FE-FF-88	1/2"	1/2"	3/8"	2.35	2.00

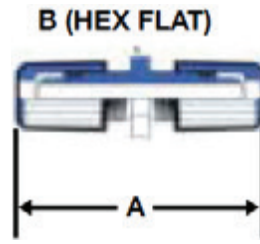

Union 101621

Part	Flare	Orifice	A Dim	B Dim
U-FF-4	1/4"	1/8"	2.38	0.75
U-FF-6	3/8"	1/4"	2.38	0.88
U-FF-8	1/2"	3/8"	2.58	1.00
U-FF-12	3/4"	5/8"	2.88	1.25
U-FF-16	1"	7/8"	3.36	1.69

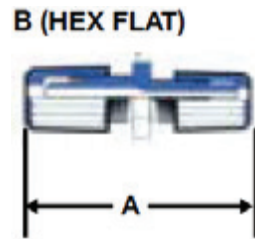

Reducing Union 106881

Part	Flare	Flare	Orifice	A Dim	B Dim
RU-FF-64	3/8"	1/4"	1/8"	2.38	.75
RU-FF-86	1/2"	3/8"	1/4"	2.60	.94
RU-FF-128	3/4"	1/2"	3/8"	2.85	1.13

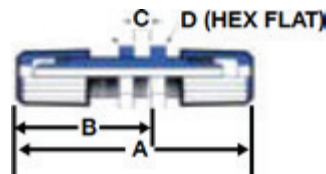

Bulkhead Union 105368

Part	Flare	Flare	Orifice	A Dim	B Dim	C Max	D Hex
BU-FF-4	1/4"	1/4"	1/8"	3.02	1.65	.50	.56
BU-FF-6	3/8"	3/8"	1/4"	3.02	1.65	.50	.75
BU-FF-8	1/2"	1/2"	3/8"	3.12	1.75	.50	.94
BU-FF-12	3/4"	3/4"	5/8"	3.27	1.90	.50	1.13

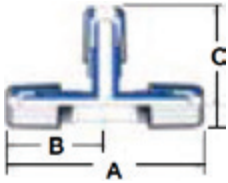

Union Tee 104591

Part	Flare	Orifice	A Dim	B Dim	C Dim
UT-FF-4	1/4"	1/8"	2.56	1.28	1.56
UT-FF-6	3/8"	1/4"	2.75	1.38	1.75
UT-FF-8	1/2"	3/8"	3.20	1.60	2.10
UT-FF-12	3/4"	5/8"	3.75	1.88	2.50

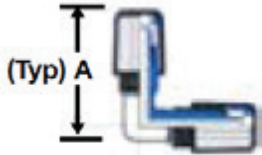

Union Elbow 108000

1/8"	Flare	Orifice	A Dim
UE-FF-4	1/4"	1/8"	1.56
UE-FF-6	3/8"	1/4"	1.75
UE-FF-8	1/2"	3/8"	2.10
UE-FF-12	3/4"	5/8"	2.50
UE-FF-16	1"	7/8"	2.99



Flare Nut 103350

Part	Flare	Orifice	A Dim
N-FF-4	1/4"	1/4"	1.05
N-FF-6	3/8"	3/8"	1.05
N-FF-8	1/2"	1/2"	1.13
N-FF-12	3/4"	3/4"	1.30
N-FF-16	1"	1"	1.50

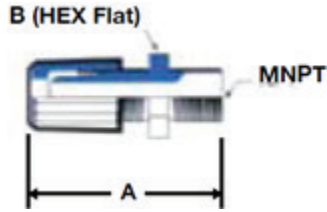

Male Connector 104950

Part	Flare	MNPT	Orifice	A Dim	B Dim
MC-FF-42	1/4"	1/8"	1/8"	1.76	.56
MC-FF-44	1/4"	1/4"	1/8"	1.94	.56
MC-FF-46	1/4"	3/8"	1/8"	2.06	.75
MC-FF-64	3/8"	1/4"	1/4"	1.94	.75
MC-FF-66	3/8"	3/8"	1/4"	1.94	.75
MC-FF-68	3/8"	1/2"	1/4"	2.25	.94
MC-FF-86	1/2"	3/8"	3/8"	2.16	.94
MC-FF-88	1/2"	1/2"	3/8"	2.35	.94
MC-FF-812	1/2"	3/4"	3/8"	2.35	1.13
MC-FF-128	3/4"	1/2"	1/2"	2.50	1.13
MC-FF-1212	3/4"	3/4"	5/8"	2.50	1.13
MC-FF-1216	3/4"	1"	7/8"	2.69	1.50

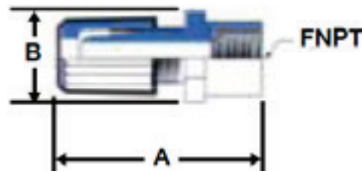

Female Connector 108586

Part	Flare	FNPT	Orifice	A Dim	B Dim
FC-FF-42	1/4"	1/8"	1/8"	1.76	.75
FC-FF-44	1/4"	1/4"	1/8"	1.94	.84
FC-FF-46	1/4"	3/8"	1/8"	1.94	1.00
FC-FF-64	3/8"	1/4"	1/4"	1.94	.84
FC-FF-66	3/8"	3/8"	1/4"	1.94	1.00
FC-FF-68	3/8"	1/2"	1/4"	2.13	1.25
FC-FF-86	1/2"	3/8"	3/8"	2.04	1.00
FC-FF-88	1/2"	1/2"	3/8"	2.23	1.25
FC-FF-812	1/2"	3/4"	3/8"	2.23	1.50
FC-FF-128	3/4"	1/2"	5/8"	2.38	1.25
FC-FF-1212	3/4"	3/4"	5/8"	2.38	1.50

iPolymer | Pipe Fittings

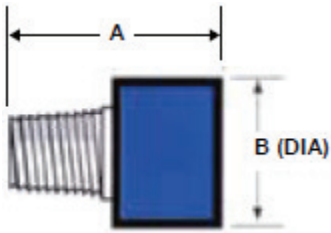

Bushing 100640

Part	MNPT	FNPT	A Dim	B Dim
B-P-42	1/4"	1/8"	1.32	.75
B-P-44	1/4"	1/4"	1.50	.84
B-P-46	1/4"	3/8"	1.50	1.00
B-P-64	3/8"	1/4"	1.50	.84
B-P-68	3/8"	1/2"	1.69	1.25
B-P-84	1/2"	1/4"	1.81	.88
B-P-86	1/2"	3/8"	1.81	1.00
B-P-124	3/4"	1/4"	1.81	1.13
B-P-128	3/4"	1/2"	2.00	1.25
B-P-1212	3/4"	3/4"	2.00	1.50

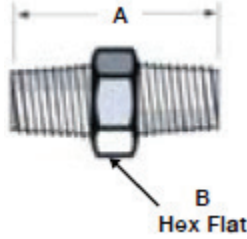

Pipe Nipple 101618

Part	MNPT	A Dim	B Dim
NP-P-2	1/8"	1.01	.44
NP-P-4	1/4"	1.50	.56
NP-P-6	3/8"	1.50	.75
NP-P-8	1/2"	2.00	.94
NP-P-12	3/4"	2.00	1.25
NP-P-16	1"	2.38	1.50

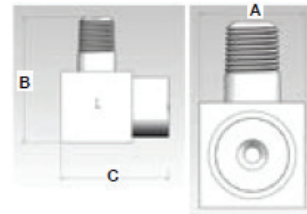

Street Elbow 104138

Part	MNPT	FNPT	A Dim	B Dim	C Dim
SE-P-4	1/4"	1/4"	.84	1.63	1.44
SE-P-6	3/8"	3/8"	1.00	1.94	1.56
SE-P-8	1/2"	1/2"	1.25	2.19	2.00
SE-P-12	3/4"	3/4"	1.50	2.44	2.25

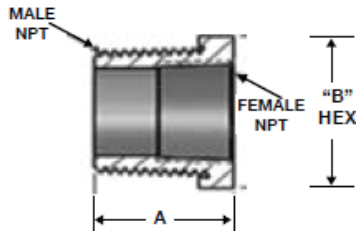

Short Bushing 103187

Part	MNPT	FNPT	A Dim	B Dim
SB-P-42	1/4"	1/8"	0.94	0.63
SB-P-82	1/2"	1/8"	1.00	0.94
SB-P-84	1/2"	1/4"	1.00	0.94
SB-P-124	3/4"	1/4"	1.00	1.25
SB-P-128	3/4"	1/2"	1.26	1.25



Elbow 101196

Part	FNPT	A Dim
E-P-4	1/4"	1.40
E-P-6	3/8"	1.56
E-P-8	1/2"	2.00
E-P-12	3/4"	2.25
E-P-16	1"	2.69

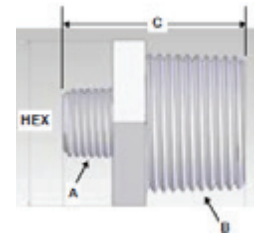

Nipple Pipe Reducer 112067

Part	A MNPT	B MNPT	Hex	C Dim
NPR-P-24	1/8"	1/4"	9/16	1.32
NPR-P-26	1/8"	3/8"	7/8	1.32
NPR-P-28	1/8"	1/2"	15/16	1.63
NPR-P-46	1/4"	3/8"	7/8	1.50
NPR-P-48	1/4"	1/2"	15/16	1.81
NPR-P-412	1/4"	3/4"	1-1/4	1.81
NPR-P-68	3/8"	1/2"	15/16	1.81
NPR-P-612	3/8"	3/4"	1-1/4	1.81
NPR-P-812	1/2"	3/4"	1-1/4	2.00



Female Reducer 101775

Part	FNPT	FNPT	A Dim	B Dim
FR-P-84	1/2"	1/4"	1.81	1.25
FR-P-86	1/2"	3/8"	1.81	1.25
FR-P-128	3/4"	1/2"	2.00	1.50

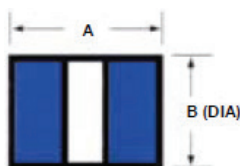

Coupling 101617

Part	FNPT	A Dim	B Dim
C-P-4	1/4"	1.56	.84
C-P-6	3/8"	1.56	.88
C-P-8	1/2"	2.06	1.13
C-P-12	3/4"	2.06	1.50

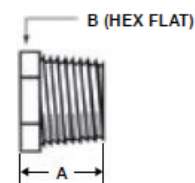

Pipe Plug 101780

Part	FNPT	A Dim	B Dim
P-P-2	1/8"	.63	.44
P-P-4	1/4"	.94	.56
P-P-6	3/8"	.94	.75
P-P-8	1/2"	1.25	.94
P-P-12	3/4"	1.25	1.25
P-P-16	1"	1.44	1.50

Materials & Chemical Compatibility

Common Chemicals	Materials									
	EPDM	Viton	Kalrez	AFLAS	CPVC	PEEK	Polypro	PVC	PVDF	PTFE
LEGEND: E = Excellent - Recommended G = Good - Minor Effects x = Not Recommended * = No References										
Acetic Acid	E	G	x	x	x	E	G	x	x	E
Acetone	E	x	E	x	x	E	E	x	x	E
Ammonia	E	x	*	*	E	G	E	E	E	E
Antifreeze	E	E	E	*	E	E	x	E	*	*
Benzene	x	E	E	x	x	E	x	x	E	E
Boric Acid	E	E	E	*	E	E	E	E	E	E
Bromine	x	E	E	*	x	x	x	x	E	E
Butanol	E	E	E	E	E	E	E	x	E	E
Chlorine	E	E	E	*	x	E	x	x	E	E
Citric Acid	E	E	E	*	G	E	E	G	E	E
Detergents - Mild	E	E	E	*	E	E	E	E	E	E
Diesel Fuel	x	E	E	*	E	E	E	E	E	E
Ethanol	E	E	E	E	G	E	E	x	*	E
Gasoline	x	E	E	*	x	*	x	x	E	E
Hydraulic Oil	x	E	E	*	*	E	x	E	E	E
Hydrochloric Acid (100%)	x	E	E	*	E	E	x	x	E	E
Hydrogen Gas	E	E	E	*	E	*	E	E	E	E
Hydrogen Peroxide	x	E	E	*	E	E	G	E	E	E
Hydrofluoric Acid (< 50%)	x	G	E	*	x	x	E	G	E	E
Hydrofluoric Acid (100%)	x	G	E	*	x	x	x	x	E	E
Isopropyl Alcohol	E	E	E	*	x	E	E	E	*	E
Methane	x	E	E	*	*	E	E	G	E	E
Natural Gas	x	E	E	*	*	E	E	E	*	E
Ozone	E	E	E	*	E	E	G	G	E	E
Petroleum	x	E	E	*	E	E	G	*	E	E
Phosphoric Acid (< 40%)	G	E	E	*	E	E	E	G	G	E
Phosphoric Acid	G	E	*	*	*	E	G	G	E	E
Propane (liquid)	x	E	E	*	E	E	E	E	E	E
Sodium Hypochlorite (Bleach)	G	E	E	*	x	G	G	G	E	E
Sulfuric Acid (< 75%)	G	E	E	*	E	x	E	E	E	E
Sulfuric Acid (75-100%)	G	E	E	*	x	x	x	x	E	E
Tetrahydrofuran	x	x	E	x	x	E	x	x	G	E
Toluene	x	x	E	x	x	E	x	x	E	E
Trichloroethane	x	E	E	x	*	E	x	x	E	E
Trichloroethylene	x	E	E	x	x	E	x	x	G	E
Water - Deionized	E	E	*	*	E	*	E	E	E	E
Water - Fresh or Salt	E	E	*	*	E	E	E	G	E	E
Zinc Chloride	E	E	E	*	E	E	E	G	E	E

Common Polymers & Uses

PTFE polytetrafluoroethylene: Material of choice for low friction applications. Excellent heat and chemical resistance. Suited for most corrosive and high temperature 240°C (460°F) applications. Chemical inertness makes it difficult to bond and weld. See TFM-1600 & PFA as high performance alternatives.

TFM Dyneon-1600 Enhanced PTFE: TFM is a modified PTFE blend. Designed for molding with good free flowing properties. Commonly used as liners in the Chemical Industry. Excellent material for sealing and seating in valve components. Good weld ability with service temperatures up to 260°C (500°F).

PFA perfluoroalkoxy: PFA has exceptional heat, chemical and weather resistance. Ideal for corrosives and high temperatures 260°C (500°F). Suitable for molding and critical components.

PVDF polyvinylidene fluoride: PVDF is ideal for a variety of applications such as pumps, valves, sheet products, pipes, tubes and fittings needing excellent chemical resistance and operating temperatures up to 150°C (300°F).

PEEK polyetheretherketone: PEEK is a strong, chemical and heat-resistant thermoplastic. Biocompatibility allows for use in medical applications. Frequently used as bearing material and as structural components in high performance plastic devices. Service temperatures up to 150°C (300°F).

POL polypropylene: POL is a common thermoplastic polymer. One of most versatile high purity polymers used in a wide variety of clean and corrosive applications. It is rugged and resistant to many chemical solvents, bases and acids. Service temperatures up to 60°C (140°F).

Hard PVC polyvinylchloride: PVC is a rigid strong polymer. PVC is common for enclosures, plumbing and flow devices. However, it will degrade with UV exposure and is susceptible to chemical corrosive attack. Service temperatures up to 70°C (160°F).



WK *i* **Polymer**
by White Knight

White Knight Fluid Handling
187 East 670 South
Kamas, UT 84036

Phone: 435.783.6040
Toll Free: 888.796.2476
Fax: 435.783.6128

info@ipolymer.com
www.ipolymer.com
www.wkfluid.com

